

Service Manual

Pioneer

KEH-P7800R/X1N/EW

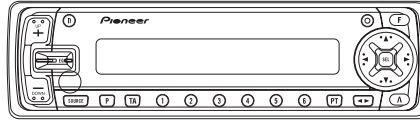

ORDER NO.
CRT2305

MULTI-CD CONTROL HIGH POWER CASSETTE PLAYER WITH RDS TUNER

KEH-P7800R

X1N/EW

KEH-P6800R

X1N/EW

NOTE:

- See the separate manual CX-631(CRT1640) for the cassette mechanism description.
- The cassette mechanism assy employed in this model is one of 2L series.
- Dolby noise reduction manufactured under license from Dolby Laboratories Licensing Corporation.
"Dolby" and the double-D symbol are trademarks of Dolby Laboratories Licensing Corporation.

CONTENTS

1. SAFETY INFORMATION	2	7. GENERAL INFORMATION	48
2. EXPLODED VIEWS AND PARTS LIST	2	7.1 PARTS.....	48
3. SCHEMATIC DIAGRAM	14	7.1.1 IC	48
4. PCB CONNECTION DIAGRAM	26	7.1.2 DISPLAY	53
5. ELECTRICAL PARTS LIST	36	7.2 DIAGNOSIS.....	54
6. ADJUSTMENT	46	7.2.1 DISASSEMBLY	54
		7.2.2 TEST MODE	55
		7.3 BLOCK DIAGRAM.....	58
		8. OPERATIONS AND SPECIFICATIONS	59

PIONEER ELECTRONIC CORPORATION 4-1, Meguro 1-Chome, Meguro-ku, Tokyo 153-8654, Japan
PIONEER ELECTRONICS SERVICE INC. P.O.Box 1760, Long Beach, CA 90801-1760 U.S.A.
PIONEER ELECTRONIC [EUROPE] N.V. Haven 1087 Keetberglaan 1, 9120 Melsele, Belgium
PIONEER ELECTRONICS ASIACENTRE PTE.LTD. 253 Alexandra Road, #04-01, Singapore 159936

1. SAFETY INFORMATION

This service manual is intended for qualified service technicians; it is not meant for the casual do-it-yourselfer. Qualified technicians have the necessary test equipment and tools, and have been trained to properly and safely repair complex products such as those covered by this manual.

Improperly performed repairs can adversely affect the safety and reliability of the product and may void the warranty. If you are not qualified to perform the repair of this product properly and safely, you should not risk trying to do so and refer the repair to a qualified service technician.

2. EXPLODED VIEWS AND PARTS LIST

2.1 PACKING

● KEH-P7800R/X1N/EW

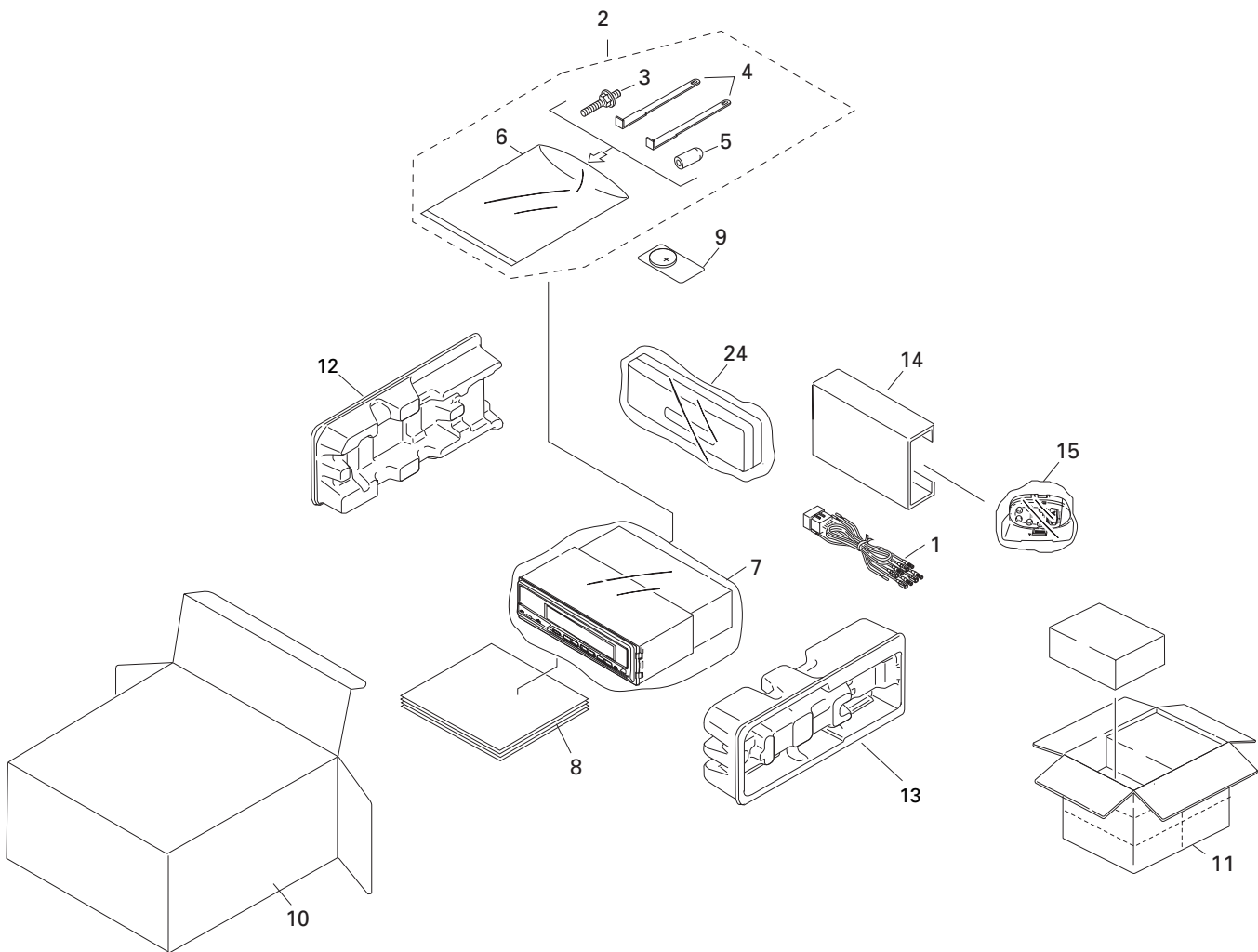

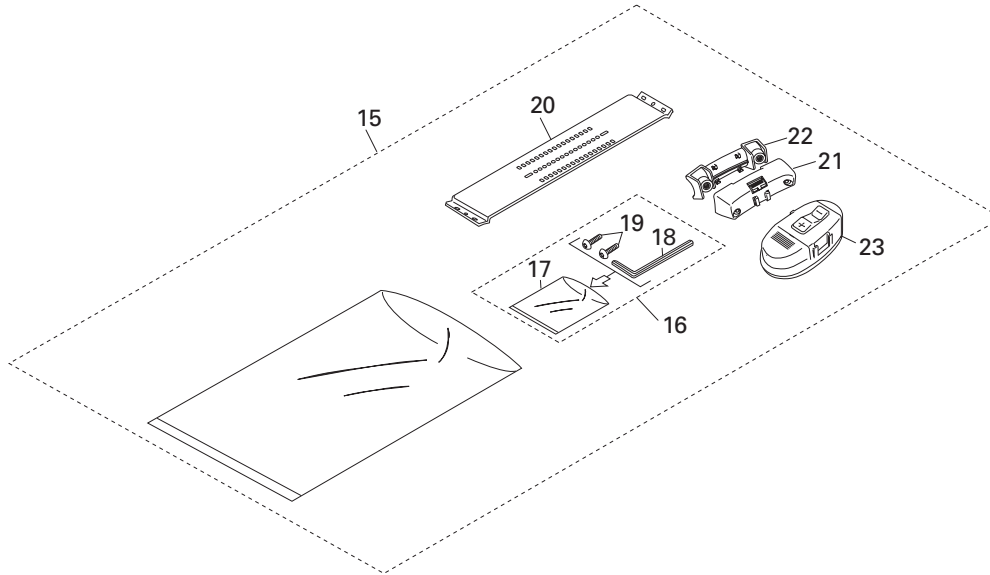

NOTE:

- Parts marked by "*" are generally unavailable because they are not in our Master Spare Parts List.
- Screws adjacent to ∇ mark on the product are used for disassembly.

● PACKING SECTION PARTS LIST

Mark No.	Description	Part No.	Mark No.	Description	Part No.
1	Cord Assy	CDE5757	9	Battery	CEX1030
2	Accessory Assy	CEA1917	10	Carton	CHG3548
3	Screw	CBA1304	11	Contain Box	CHL3548
4	Handle	CNC5395	12	Protector	CHP2101
5	Bush	CNV3930	13	Protector	CHP2102
*	6 Polyethylene Bag	E36-615	14	Inner Box	CHW1754
7	Polyethylene Bag	CEG-162	15	Remote Control Assy	CXB3488
8-1	Owner's Manual	CRD2744	16	Screw Assy	CZE3169
8-2	Owner's Manual	CRD2745	*	17 Polyethylene Bag	CEG-127
8-3	Owner's Manual	CRD2746	*	18 Hexagonal Wrench	CZE3176
8-4	Installation Manual	CRD2747	*	19 Screw	RMZ30H060FBK
8-5	Installation Manual	CRD2748	20	Belt	CZN6416
8-6	Installation Manual	CRD2749	21	Holder Assy	CZX3172
*	8-7 Passport	CRY1013	22	Holder Assy	CZX3173
*	8-8 Warranty Card	CRY1087	23	Remote Control Assy	CZX3231
			24	Case Assy	CXB3520

● Owner's Manual, Installation Manual

Model	Part No.	Language
KEH-P7800R/X1N/EW	CRD2744,2747	English, Spanish
	CRD2745,2748	German, French
	CRD2746,2749	Italian, Dutch

KEH-P7800R,P6800R

● KEH-P6800R/X1N/EW

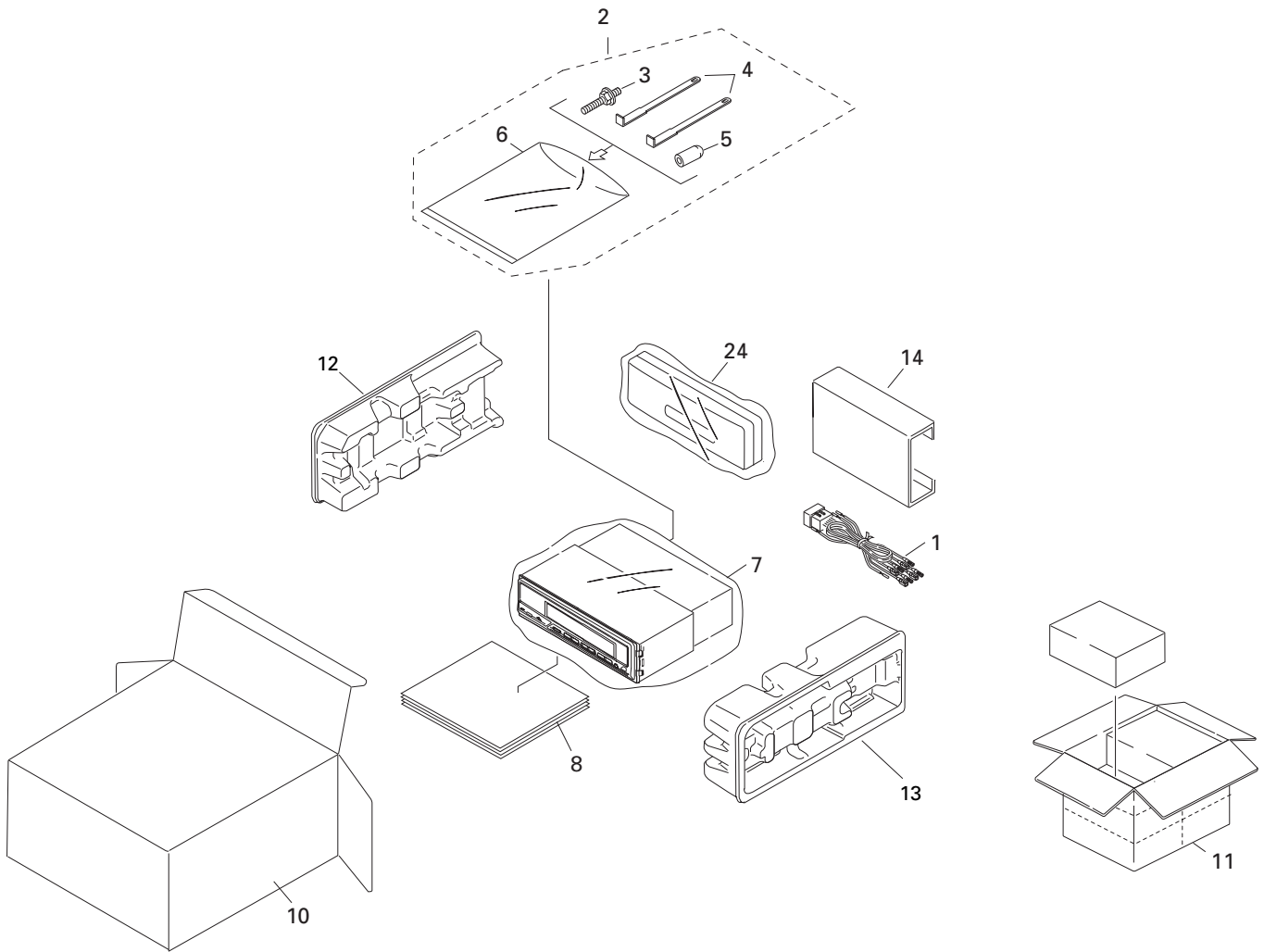

● **PACKING SECTION PARTS LIST**

Mark No.	Description	Part No.	Mark No.	Description	Part No.
1	Cord Assy	CDE5757	9	●●●●●	
2	Accessory Assy	CEA1917	10	Carton	CHG3674
3	Screw	CBA1304	11	Contain Box	CHL3674
4	Handle	CNC5395	12	Protector	CHP2101
5	Bush	CNV3930	13	Protector	CHP2102
*	6 Polyethylene Bag	E36-615	14	Inner Box	CHW1754
	7 Polyethylene Bag	CEG-162	15-23	●●●●●	
8-1	Owner's Manual	CRD2750	24	Case Assy	CXB3520
8-2	Owner's Manual	CRD2751			
8-3	Owner's Manual	CRD2752			
8-4	Installation Manual	CRD2753			
8-5	Installation Manual	CRD2754			
8-6	Installation Manual	CRD2755			
*	8-7 Passport	CRY1013			
*	8-8 Warranty Card	CRY1087			

● **Owner's Manual, Installation Manual**

Model	Part No.	Language
KEH-P6800R/X1N/EW	CRD2750,2753	English, Spanish
	CRD2751,2754	German, French
	CRD2752,2755	Italian, Dutch

2.2 EXTERIOR

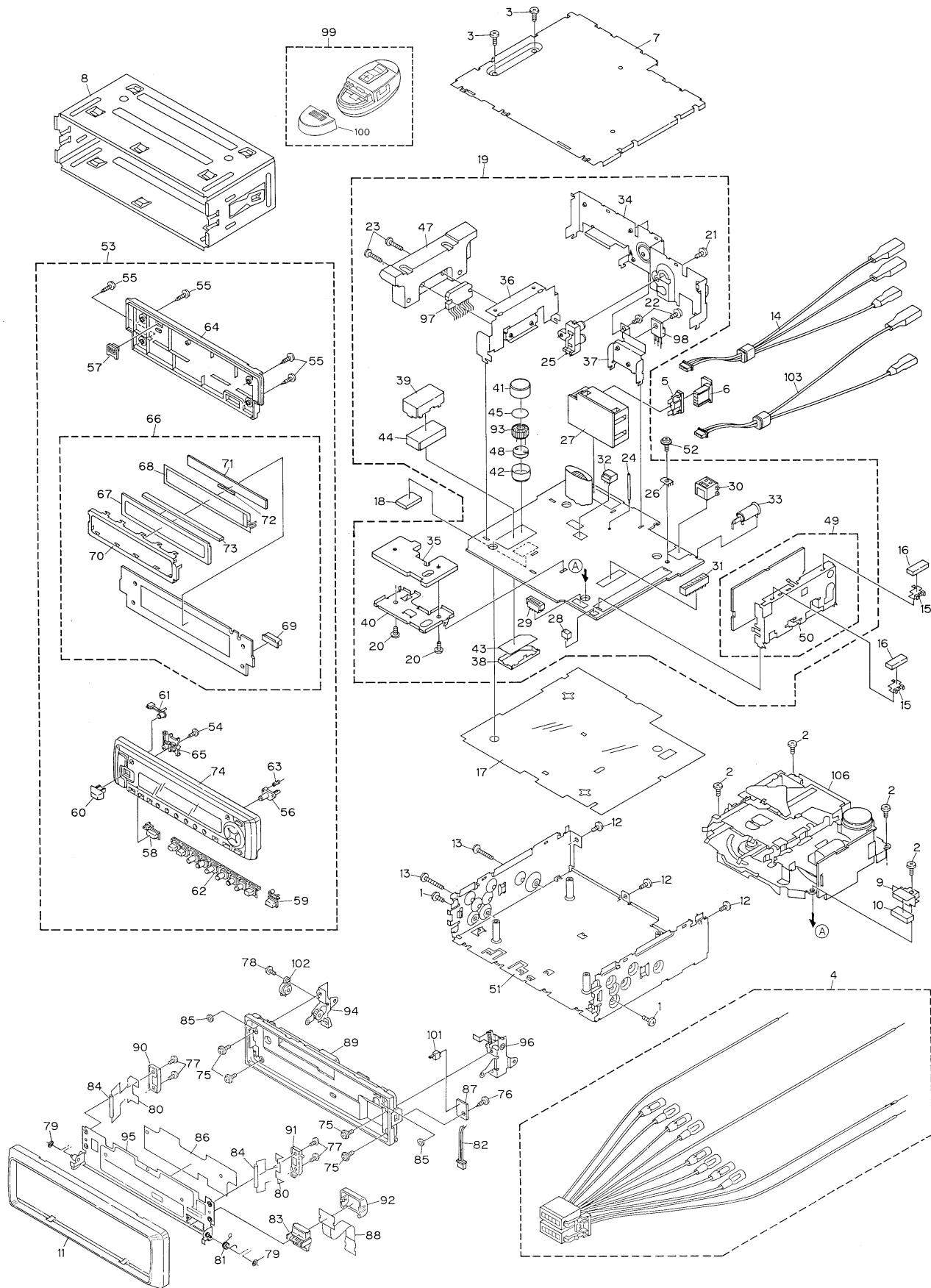

(1) EXTERIOR SECTION PARTS LIST

Mark No.	Description	Part No.	Mark No.	Description	Part No.
1	Screw	BMZ30P040FMC	46	•••••	
2	Screw	BSZ26P050FMC	47	Heat Sink	CNR1505
3	Screw	BSZ30P050FMC	48	Insulator	CNV5792
4	Cord Assy	CDE5757	49	FM/AM Tuner Unit	CWE1466
5	Fuse(10A)	CEK1136	50	Holder	CNC6554
6	Plug	CKM1290	51	Chassis Unit	See Contrast table(2)
7	Case	CNB2350	52	Screw	ISS26P055FUC
8	Holder	CNC6798	53	Detach Grille Assy	See Contrast table(2)
9	Shield	CNC7365	54	Screw	BPZ20P060FMC
10	Spacer	CNM5488	55	Screw	BPZ20P080FZK
11	Panel	CNS5148	56	Button(OPEN)	CAC5804
12	Screw	BSZ30P050FMC	57	Button(EJECT)	CAC5805
13	Screw	BSZ30P200FMC	58	Button(SOURCE)	CAC5806
14	Cord	See Contrast table(2)	59	Button(BAND)	CAC5807
15	Holder	CNC5704	60	Button(EQ)	CAC5808
16	Cushion	CNM4870	61	Button(DISP)	CAC5809
17	Insulator	CNM6275	62	Button(1-6)	CAC5921
18	Insulator	CNV5793	63	Spring	CBH2205
19	Tuner Amp Unit	See Contrast table(2)	64	Cover	CNS5146
20	Screw	BMZ26P040FMC	65	Holder	CNV5537
21	Screw	BPZ26P060FMC	66	Keyboard Unit	CWM6266
22	Screw	BSZ26P060FMC	67	LCD(LCD901)	CAW1501
23	Screw	BSZ26P160FMC	68	EL	CEL1587
24	Clamper	CEF1005	69	Connector(CN901)	CKS2733
25	Pin Jack(CN301)	CKB1028	70	Holder	CNC7992
26	Terminal(CN403)	CKF1059	71	Tape	CNM6348
27	Plug(CN952)	CKM1288	72	Spacer	CNM6347
28	Plug(CN604)	CKS-783	73	Connector	CNV5536
29	Connector(CN601)	CKS1499	74	Grille Unit	See Contrast table(2)
30	Connector(CN751)	CKS3408	75	Screw	IMS20P040FZK
31	Connector(CN602)	CKS3568	76	Screw	BPZ20P060FMC
32	Connector(CN603)	CKS3597	77	Screw	CBA1082
33	Antenna Jack(CN402)	CKX1056	78	Screw	CBA1176
34	Panel	CNB2356	79	Washer	CBF1001
35	Heat Sink	CNC7991	80	Spring	CBH2063
36	Holder	CNC7996	81	Spring	CBH2204
37	Holder	CNC7997	82	Cord	CDE5800
38	Case	CNC7998	83	Connector	CKS2780
39	Case	CNC8254	84	Roller	CLA3386
40	Holder	CNC8255	85	Cushion	CNM5486
41	Case	CNC8350	86	Sheet	CNM6109
42	Case	CNC8351	87	PCB	CNP5430
43	Insulator	CNM6099	88	PCB	CNP5444
44	Insulator	CNM6190	89	Panel	CNS5147
45	Insulator	CNM6257	90	Holder	CNS5157

KEH-P7800R,P6800R

Mark No.	Description	Part No.
91	Holder	CNS5165
92	Holder	CNS5389
93	Coil(L801)	CTH1227
94	Holder Unit	CXB3049
95	Holder Unit	CXB3050
96	Holder Unit	CXB3051
97	IC(IC301)	PAL005A
98	Transistor(Q951)	2SD2396
99	Remote Control Assy	CZX3231
100	Cover	CZN6410
101	Switch(S602)	CSN1027
102	Damper Unit	CXB3180
103	Cord	See Contrast table(2)
104,105	●●●●●	
106	Cassette Mechanism Module	See Contrast table(2)

(2) CONTRAST TABLE

KEH-P7800R/X1N/EW and KEH-P6800R/X1N/EW are constructed the same except for the following:

Mark No.	Description	Part No.	
		KEH-P7800R/X1N/EW	KEH-P6800R/X1N/EW
14	Cord	CDE5761	Not used
19	Tuner Amp Unit	CWM6062	CWM6151
51	Chassis Unit	CXB3047	CXB3057
53	Detach Grille Assy	CXB3435	CXB3441
74	Grille Unit	CXB3479	CXB3485
103	Cord	Not used	CDE5801
106	Cassette Mechanism Module	EXK3990	EXK3995

2.3 CASSETTE MECHANISM MODULE(KEH-P7800R/X1N/EW)

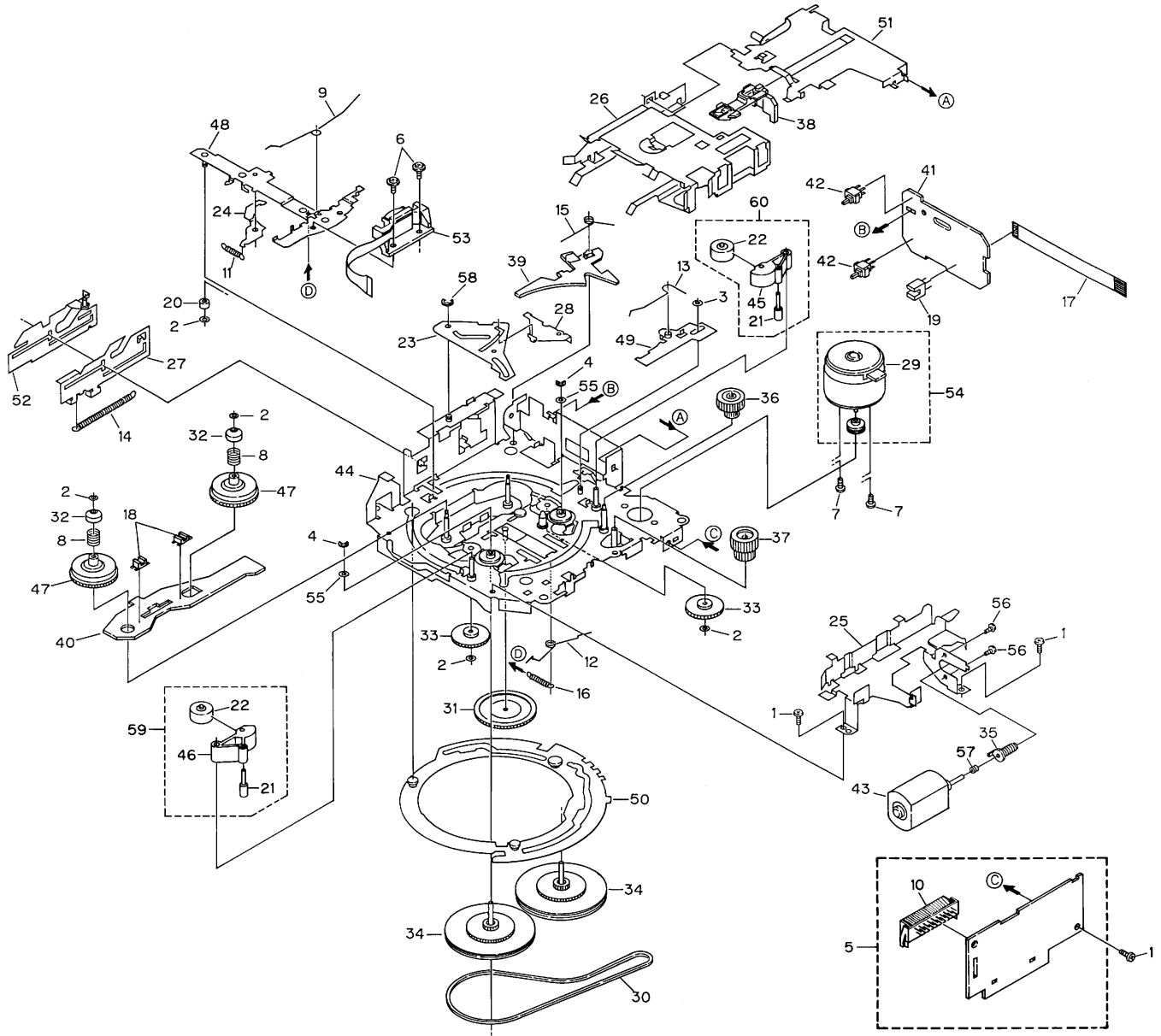

● CASSETTE MECHANISM MODULE SECTION PARTS LIST(KEH-P7800R/X1N/EW)

Mark No.	Description	Part No.	Mark No.	Description	Part No.
1	Screw	BSZ20P040FMC	31	Gear	ENV1347
2	Washer	CBF1037	32	Collar	ENV1508
3	Washer	CBF1038	33	Gear	ENV1350
4	Washer	CBG1003	34	Flywheel	ENV1500
5	Deck Unit	EWM1018	35	Worm Gear	ENV1439
6	Screw	EBA1028	36	Worm Wheel	ENV1440
7	Screw	EBA1037	37	Gear	ENR1037
8	Spring	EBH1531	38	Lever	ENV1442
9	Spring	EBH1575	39	Arm	ENV1525
10	Plug(CN251)	CKS3540	40	Gathering PCB	ENX1037
11	Spring	EBH1515	41	Gathering PCB	ENX1042
12	Spring	EBH1587	42	Switch(S1,S2)	ESG1004
13	Spring	EBH1517	43	Motor Unit(M2)	EXA1485
14	Spring	EBH1518	44	Chassis Unit	EXA1567
15	Spring	EBH1519	45	Pinch Holder	ENV1485
16	Spring	EBH1537	46	Pinch Holder	ENV1486
17	Cord	EDD1020	47	Reel Unit	EXA1543
18	Photo-interrupter(EGN2,3)	EGN1006	48	Head Base Unit	EXA1457
19	Photo-interrupter(EGN1)	EGN1005	49	Lever Unit	EXA1438
20	Roller	ENR1031	50	Gear Unit	EXA1545
21	Shaft	ELA1373	51	Frame Unit	EXA1458
22	Pinch Roller	ENV1518	52	Lever Unit	EXA1439
23	Arm	ENC1489	53	Head Assy(HD1)	EXA1506
24	Arm	ENC1397	54	Motor Unit(M1)	EXA1490
25	Guide	ENC1481	55	Washer	HBF-179
26	Holder	ENC1417	56	Screw	BMZ20P022FMC
27	Lever	ENC1448	57	Spring	EBH1545
28	Arm	ENC1488	58	Washer	YE20FUC
* 29	Motor	EXM1031	59	Pinch Holder Unit	EXA1529
30	Belt	ENT1027	60	Pinch Holder Unit	EXA1528

2.4 CASSETTE MECHANISM MODULE(KEH-P6800R/X1N/EW)

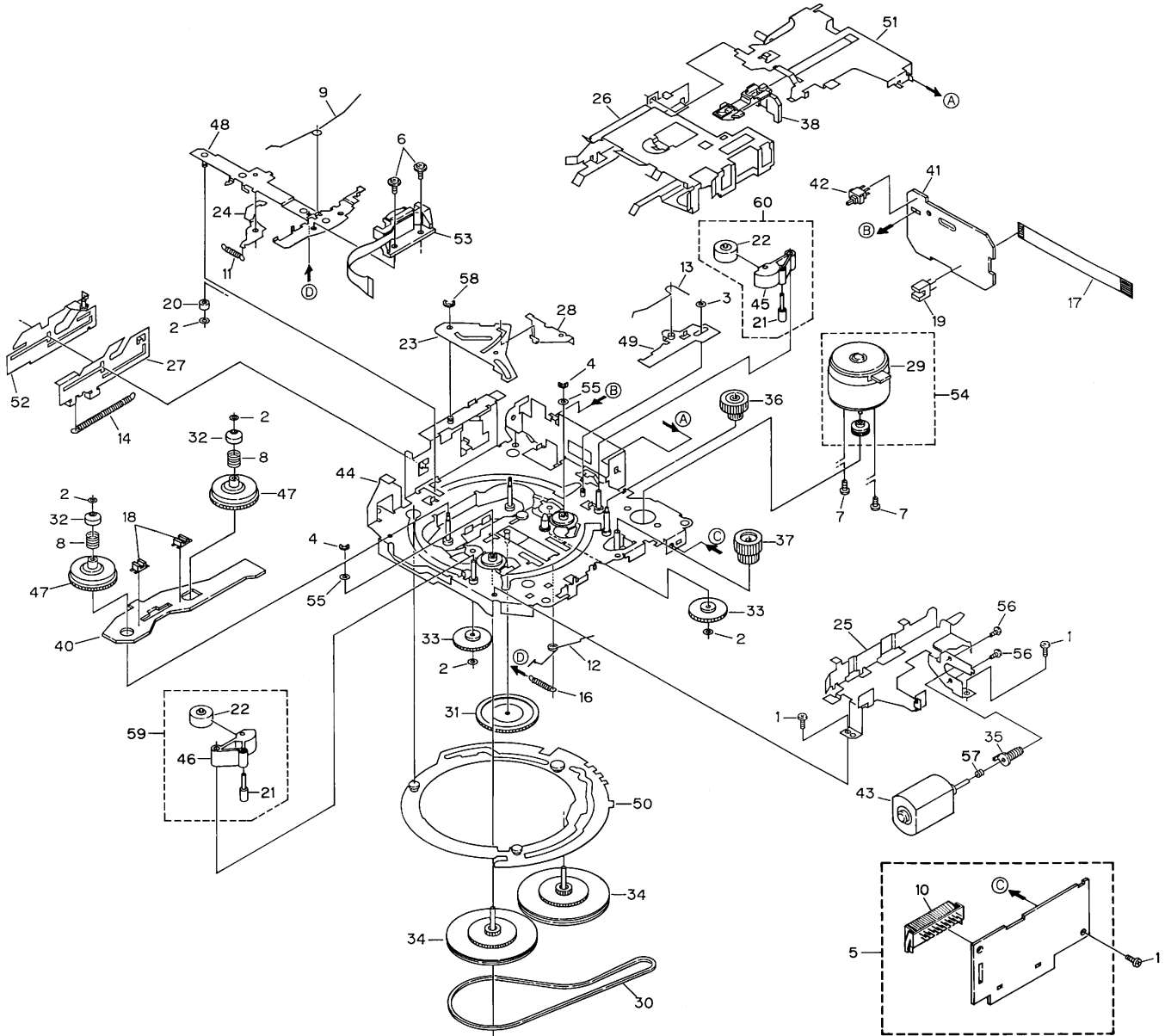

● CASSETTE MECHANISM MODULE SECTION PARTS LIST(KEH-P6800R/X1N/EW)

Mark No.	Description	Part No.	Mark No.	Description	Part No.
1	Screw	BSZ20P040FMC	31	Gear	ENV1347
2	Washer	CBF1037	32	Collar	ENV1508
3	Washer	CBF1038	33	Gear	ENV1350
4	Washer	CBG1003	34	Flywheel	ENV1500
5	Deck Unit	EWM1021	35	Worm Gear	ENV1439
6	Screw	EBA1028	36	Worm Wheel	ENV1440
7	Screw	EBA1037	37	Gear	ENR1037
8	Spring	EBH1531	38	Lever	ENV1442
9	Spring	EBH1575	39	
10	Plug(CN251)	CKS3540	40	Gathering PCB	ENX1037
11	Spring	EBH1515	41	Gathering PCB	ENX1042
12	Spring	EBH1587	42	Switch(S1)	ESG1004
13	Spring	EBH1517	43	Motor Unit(M2)	EXA1485
14	Spring	EBH1518	44	Chassis Unit	EXA1567
15		45	Pinch Holder	ENV1485
16	Spring	EBH1537	46	Pinch Holder	ENV1486
17	Cord	EDD1020	47	Reel Unit	EXA1543
18	Photo-interrupter(EGN2,3)	EGN1006	48	Head Base Unit	EXA1457
19	Photo-interrupter(EGN1)	EGN1005	49	Lever Unit	EXA1438
20	Roller	ENR1031	50	Gear Unit	EXA1574
21	Shaft	ELA1373	51	Frame Unit	EXA1458
22	Pinch Roller	ENV1518	52	Lever Unit	EXA1439
23	Arm	ENC1489	53	Head Assy(HD1)	EXA1506
24	Arm	ENC1397	54	Motor Unit(M1)	EXA1490
25	Guide	ENC1481	55	Washer	HBF-179
26	Holder	ENC1417	56	Screw	BMZ20P022FMC
27	Lever	ENC1448	57	Spring	EBH1545
28	Arm	ENC1488	58	Washer	YE20FUC
* 29	Motor	EXM1031	59	Pinch Holder Unit	EXA1529
30	Belt	ENT1027	60	Pinch Holder Unit	EXA1528

3. SCHEMATIC DIAGRAM

3.1 OVERALL CONNECTION DIAGRAM (GUIDE PAGE)

Note: When ordering service parts, be sure to refer to "EXPLODED VIEWS AND PARTS LIST" or "ELECTRICAL PARTS LIST".

A-a

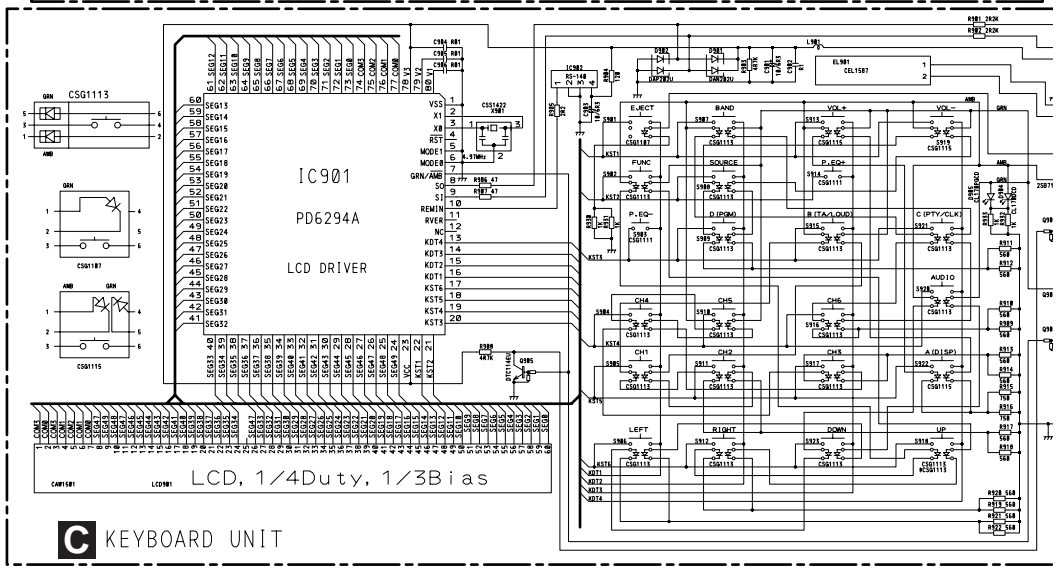
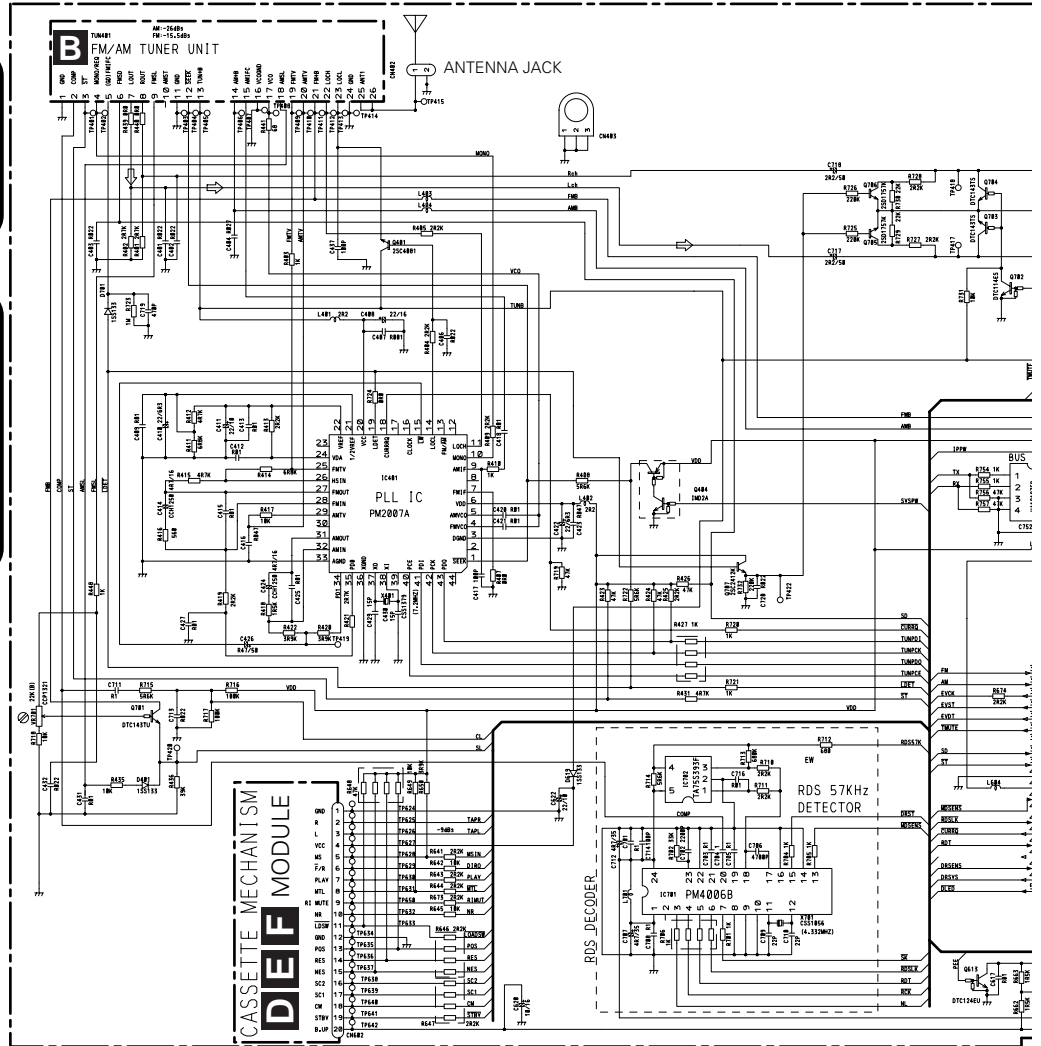
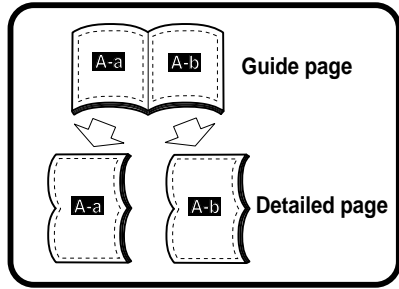
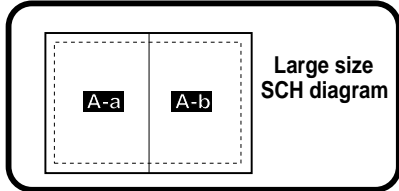

A-b

A TUNER AMP UNIT

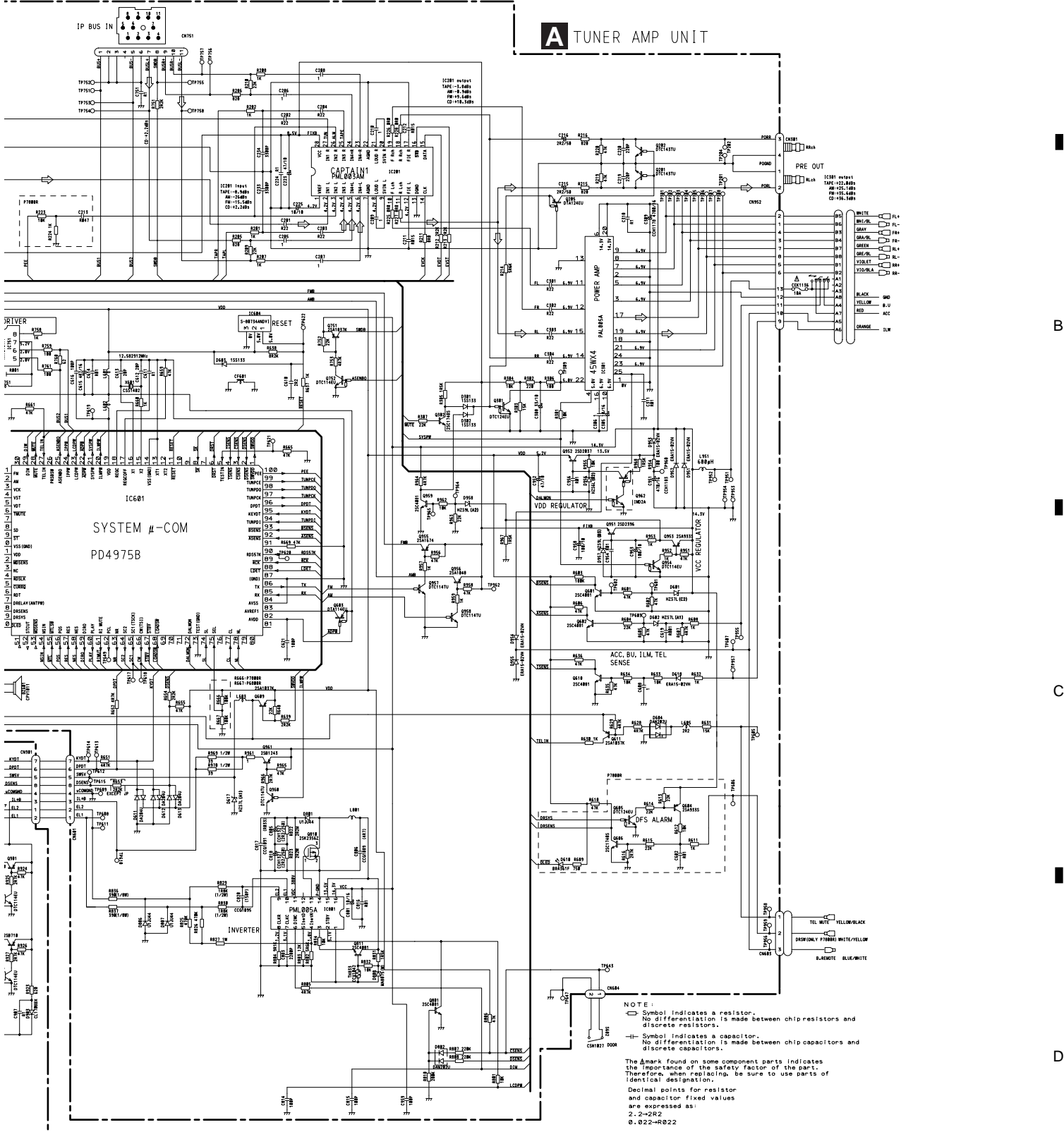

A

B

C

D

A-a A-b

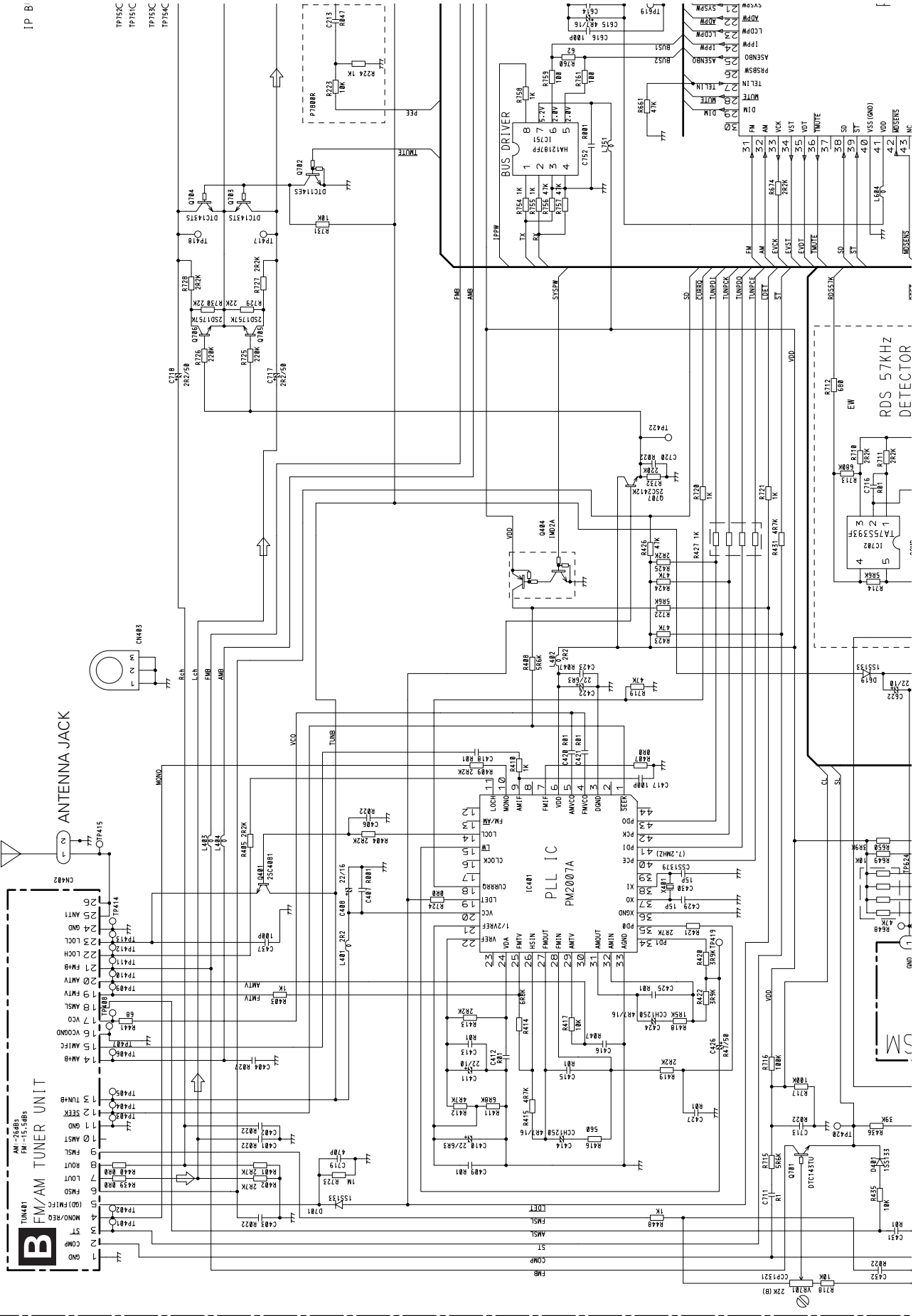

A

B

C

D

A-a A-b

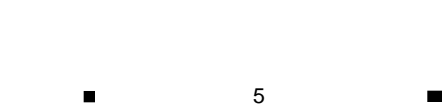
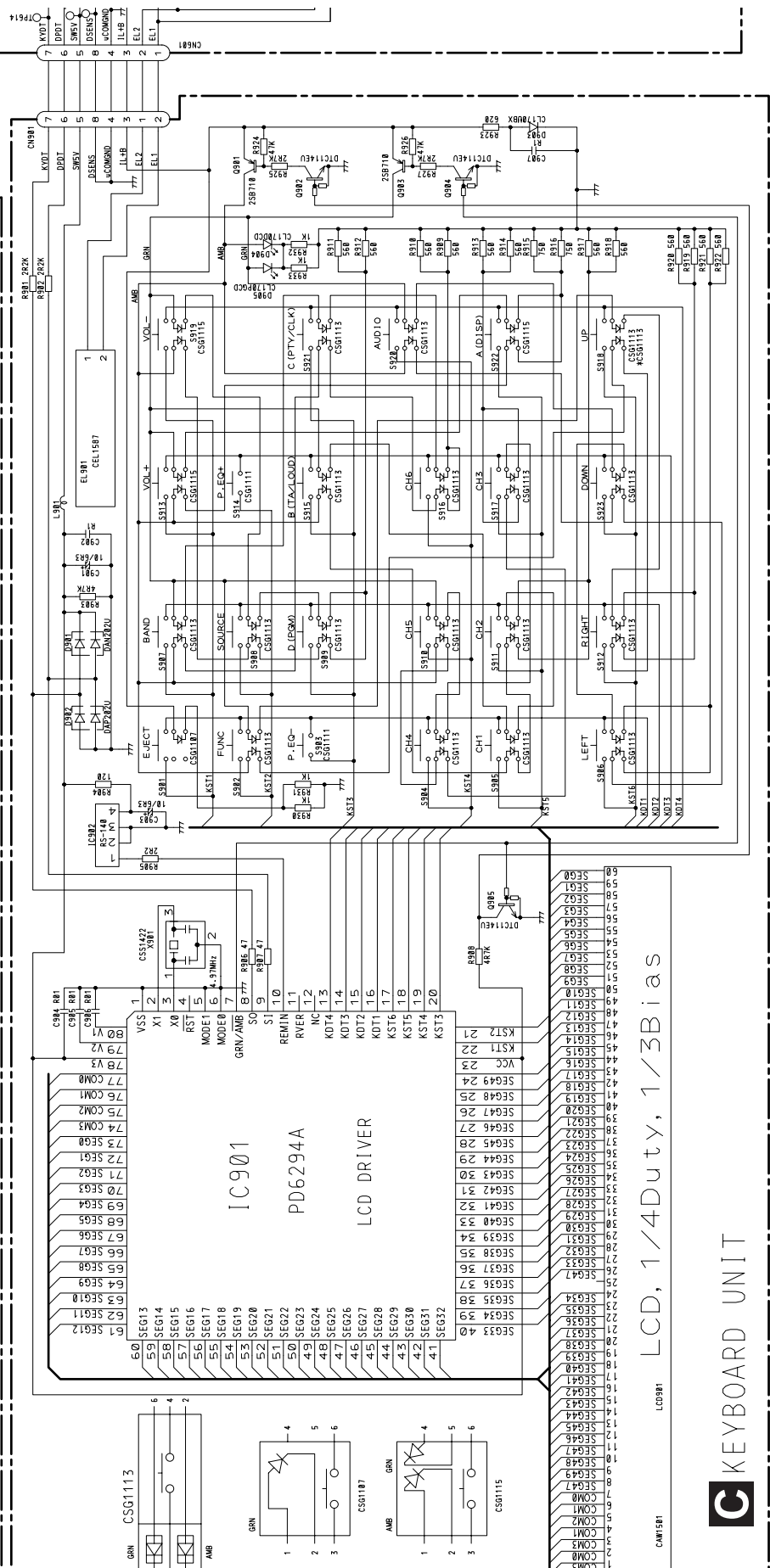
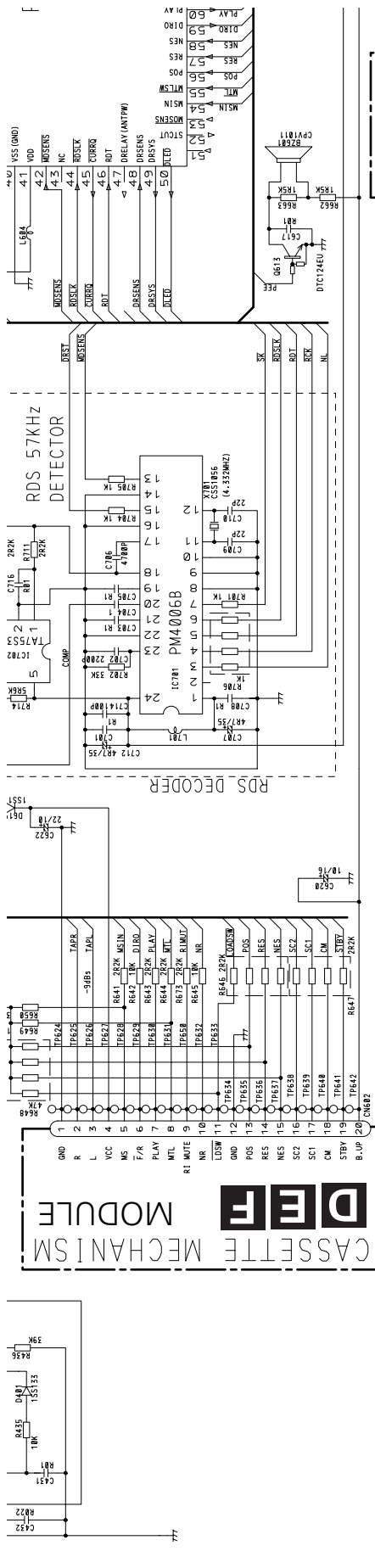

A B C D

A-a C

A TUNER AMP UNIT

A-a
A-b

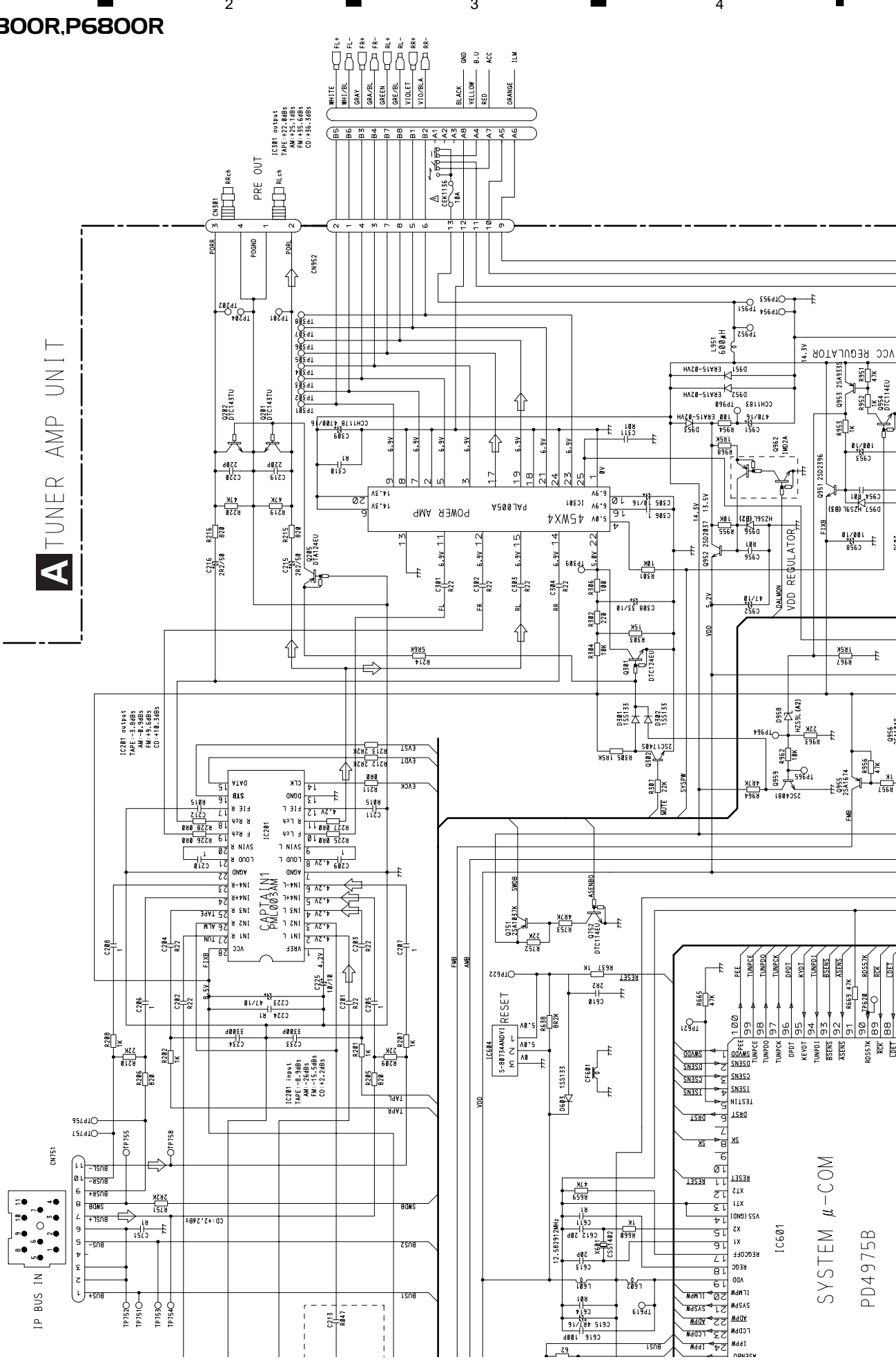

A-b

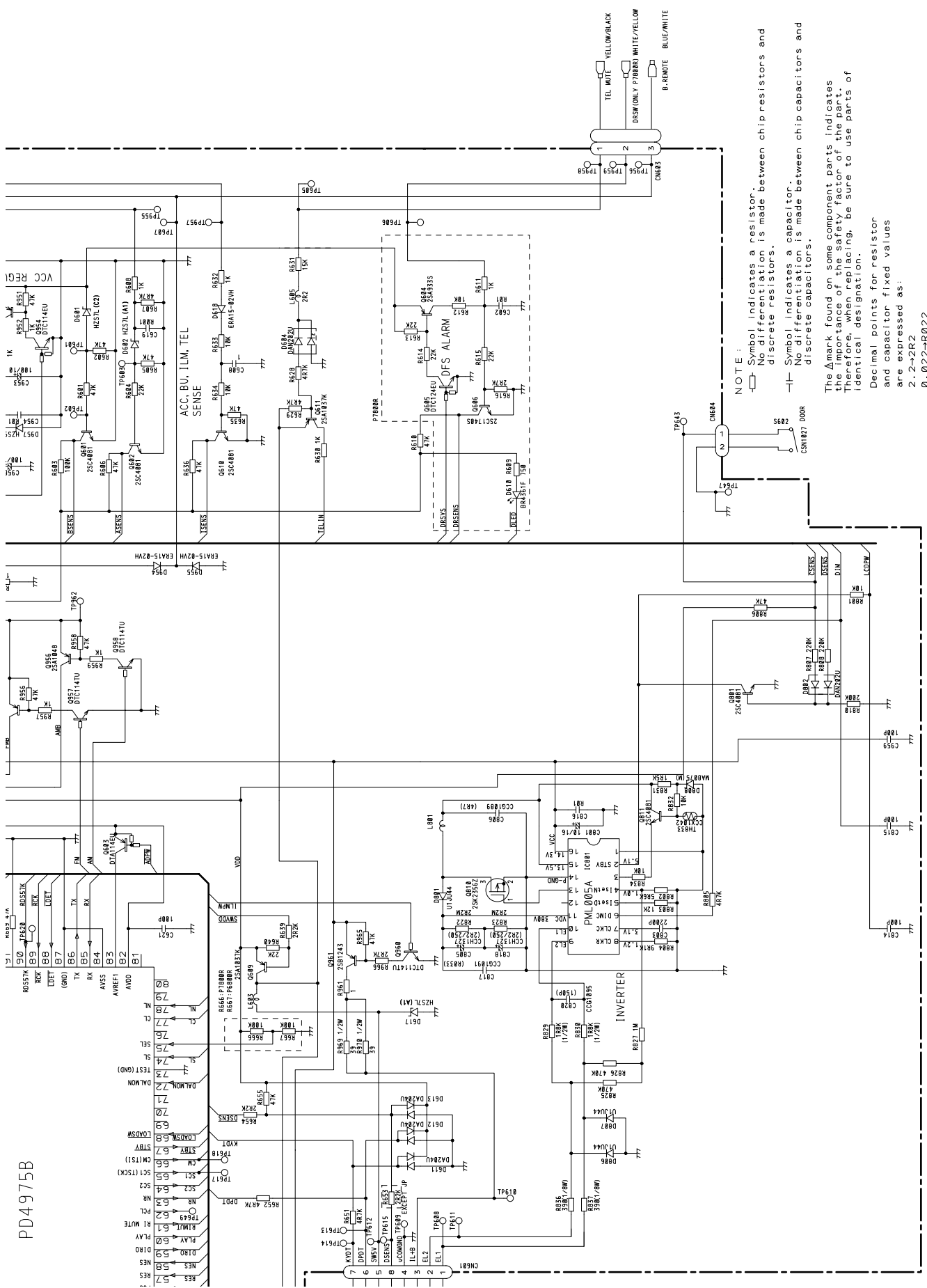

NOTE:

- Symbol indicates a resistor. No differentiation is made between chip resistors and discrete resistors.
- Symbol indicates a capacitor. No differentiation is made between chip capacitors and discrete capacitors.

The Δ mark found on some component parts indicates the importance of the safety factor of the part. Therefore, when replacing, be sure to use parts of identical designation.

Decimal points for resistor and capacitor fixed values are expressed as:
 2.2→R2
 0.022→R022

A-a A-b

A-b

3.2 FM/AM TUNER UNIT

A

B

C

D

B FM/AM TUNER UNIT

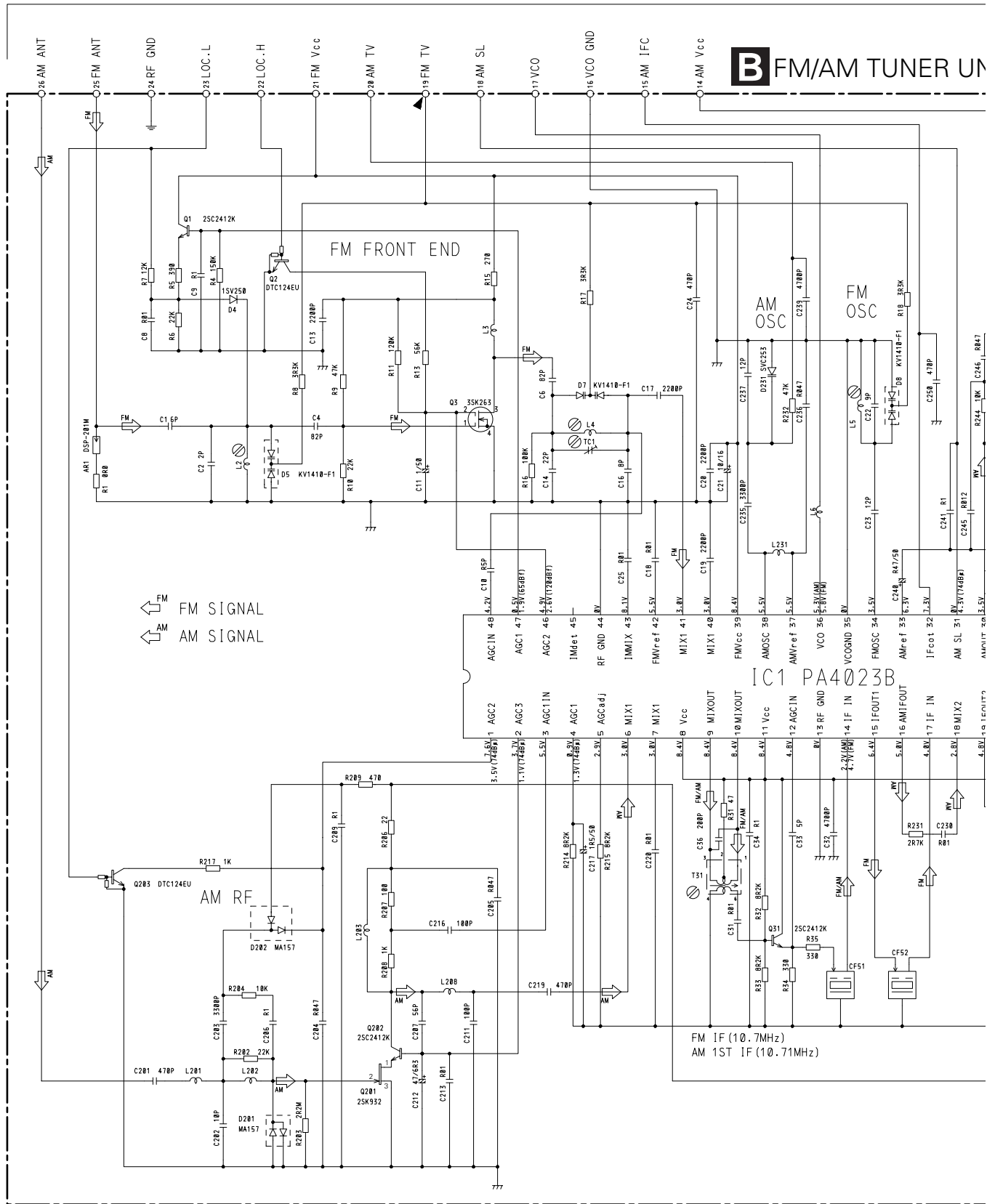

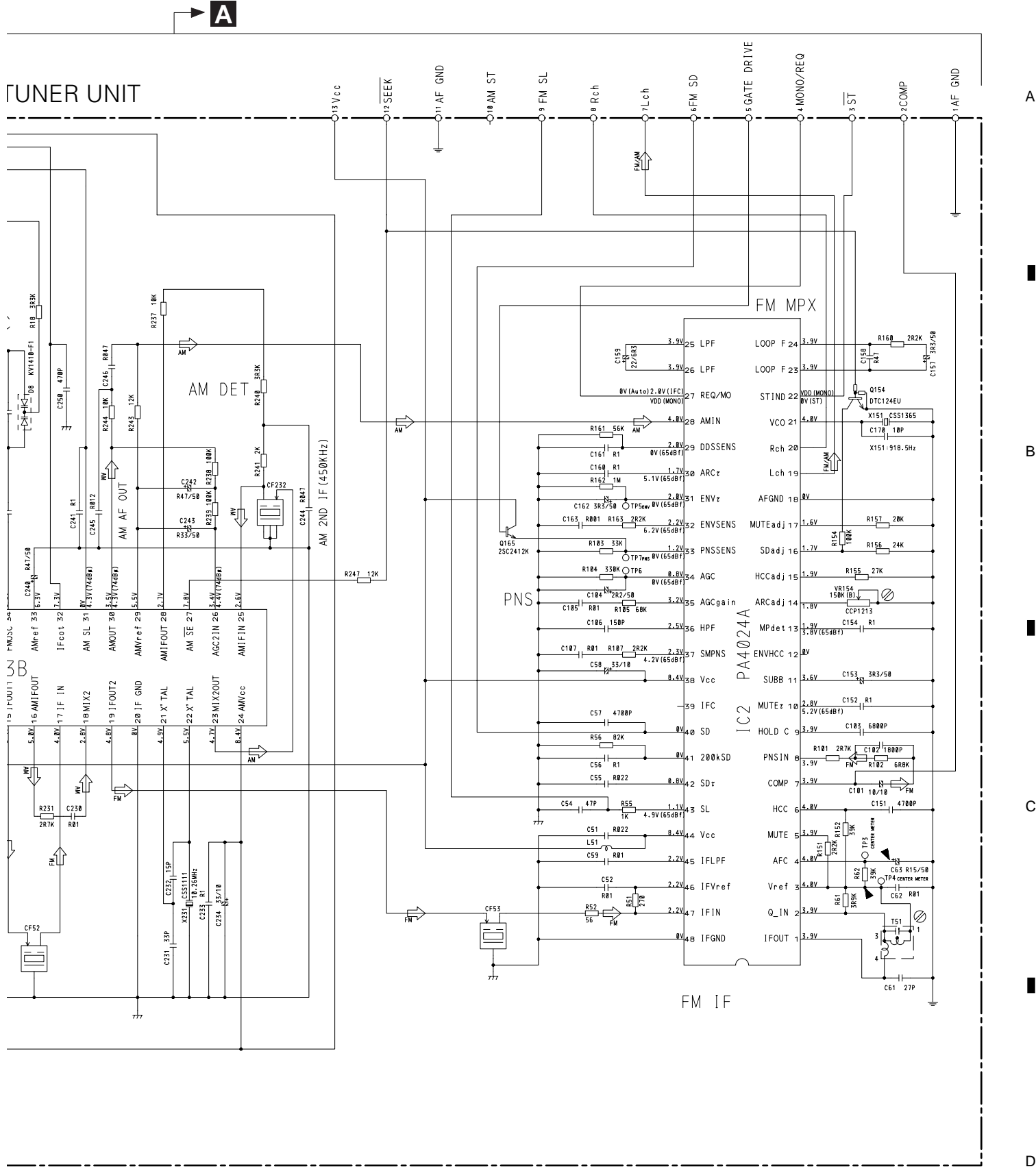

A

A

B

C

D

B

3.3 CASSETTE MECHANISM MODULE(KEH-P7800R/X1N/EW)

D DECK UNIT

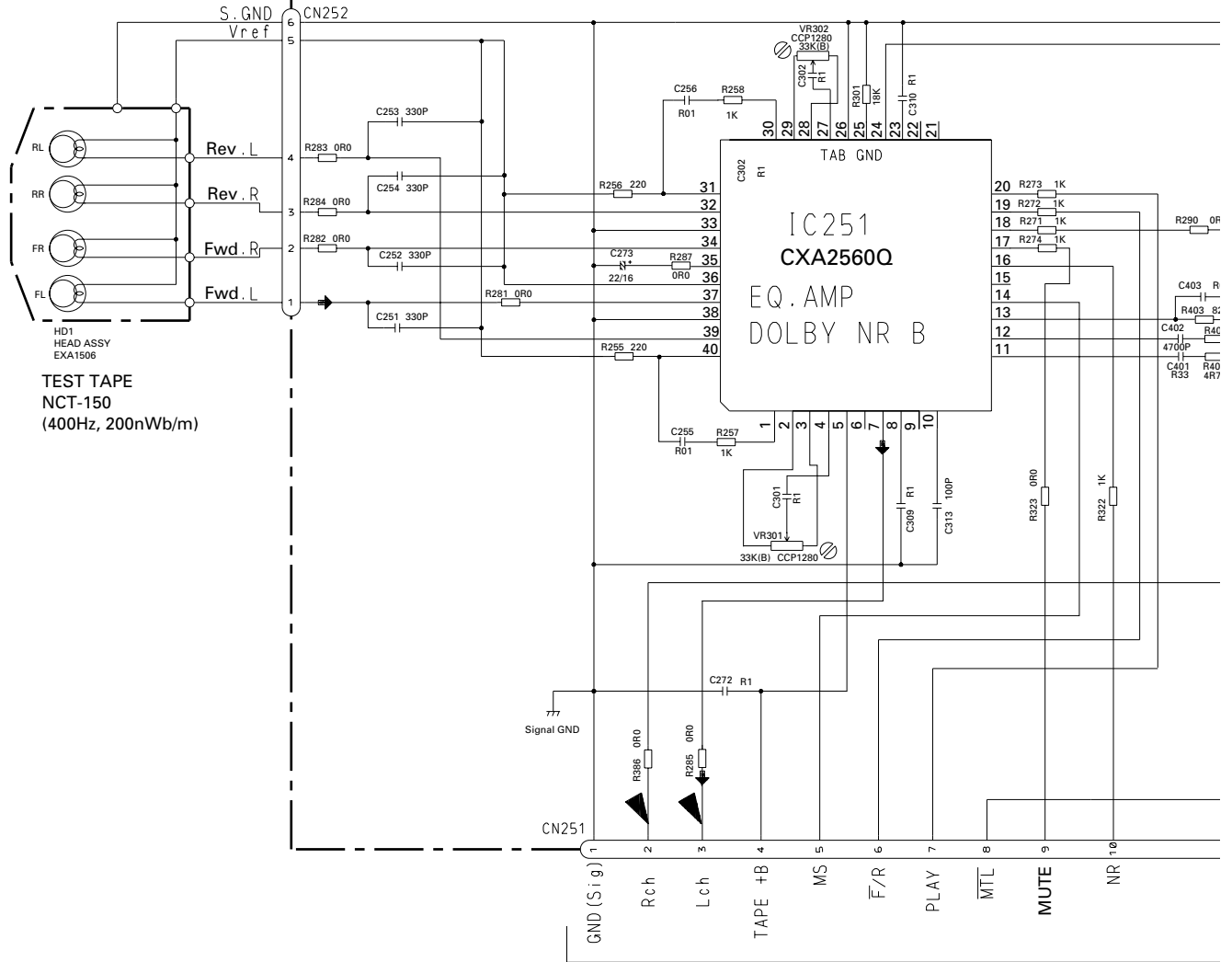

-6dBs(388mV)±1dB

A CN602

E PCB UNIT

F REEL PCB

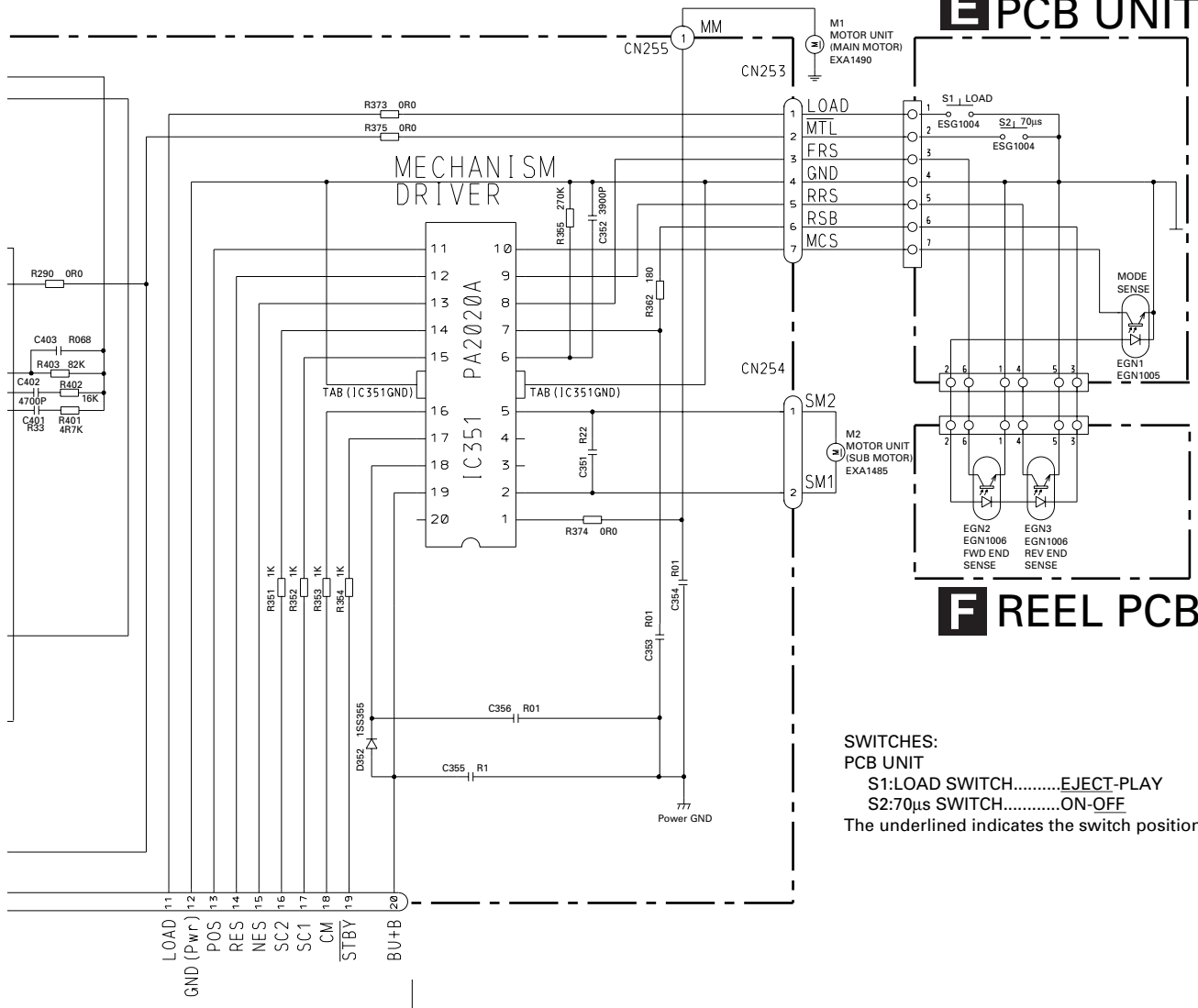

SWITCHES:
 PCB UNIT
 S1:LOAD SWITCH.....EJECT-PLAY
 S2:70µs SWITCH.....ON-OFF
 The underlined indicates the switch position.

3.4 CASSETTE MECHANISM MODULE(KEH-P6800R/X1N/EW)

D DECK UNIT

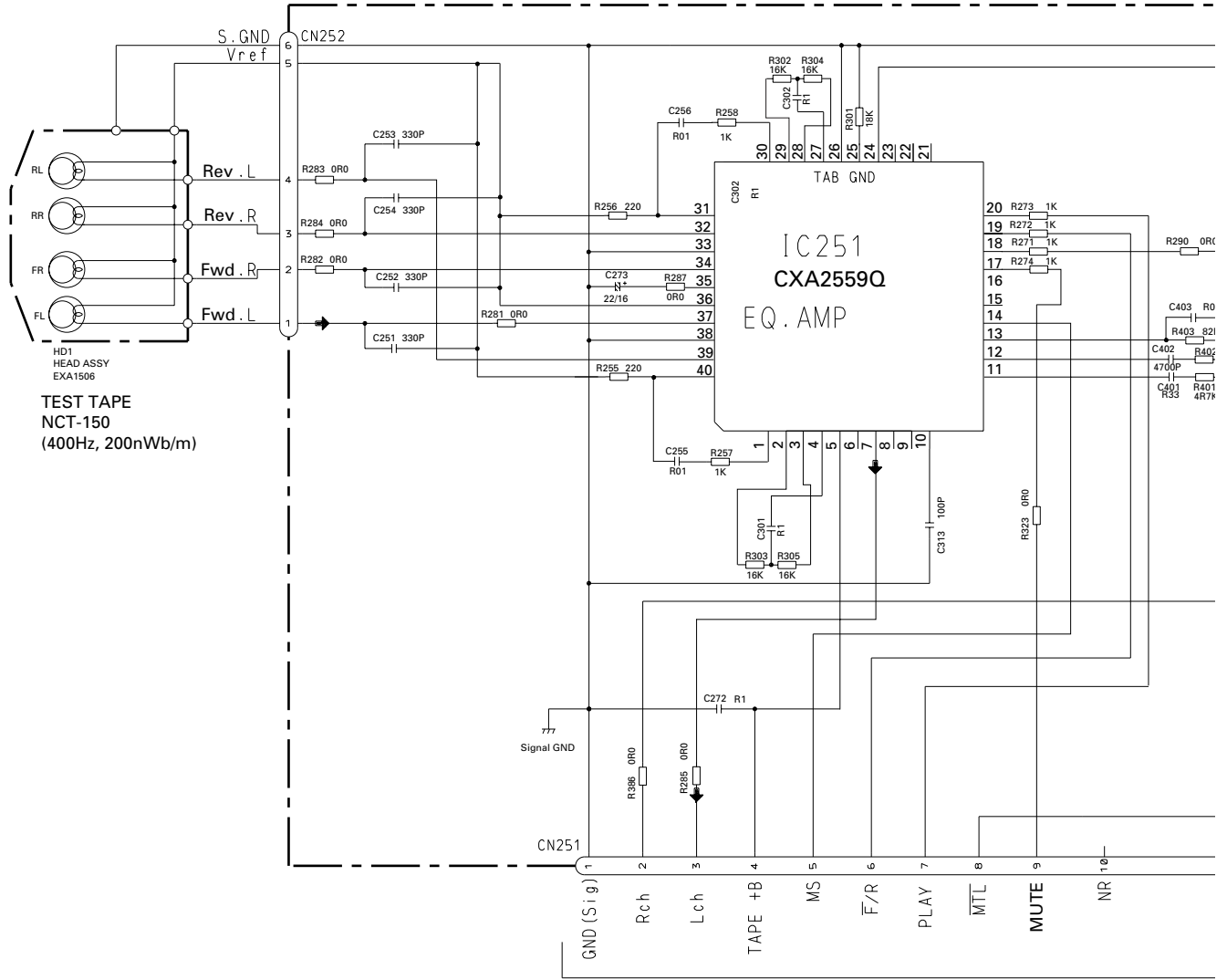

-6dBs(388mV)±1dB

A CN602

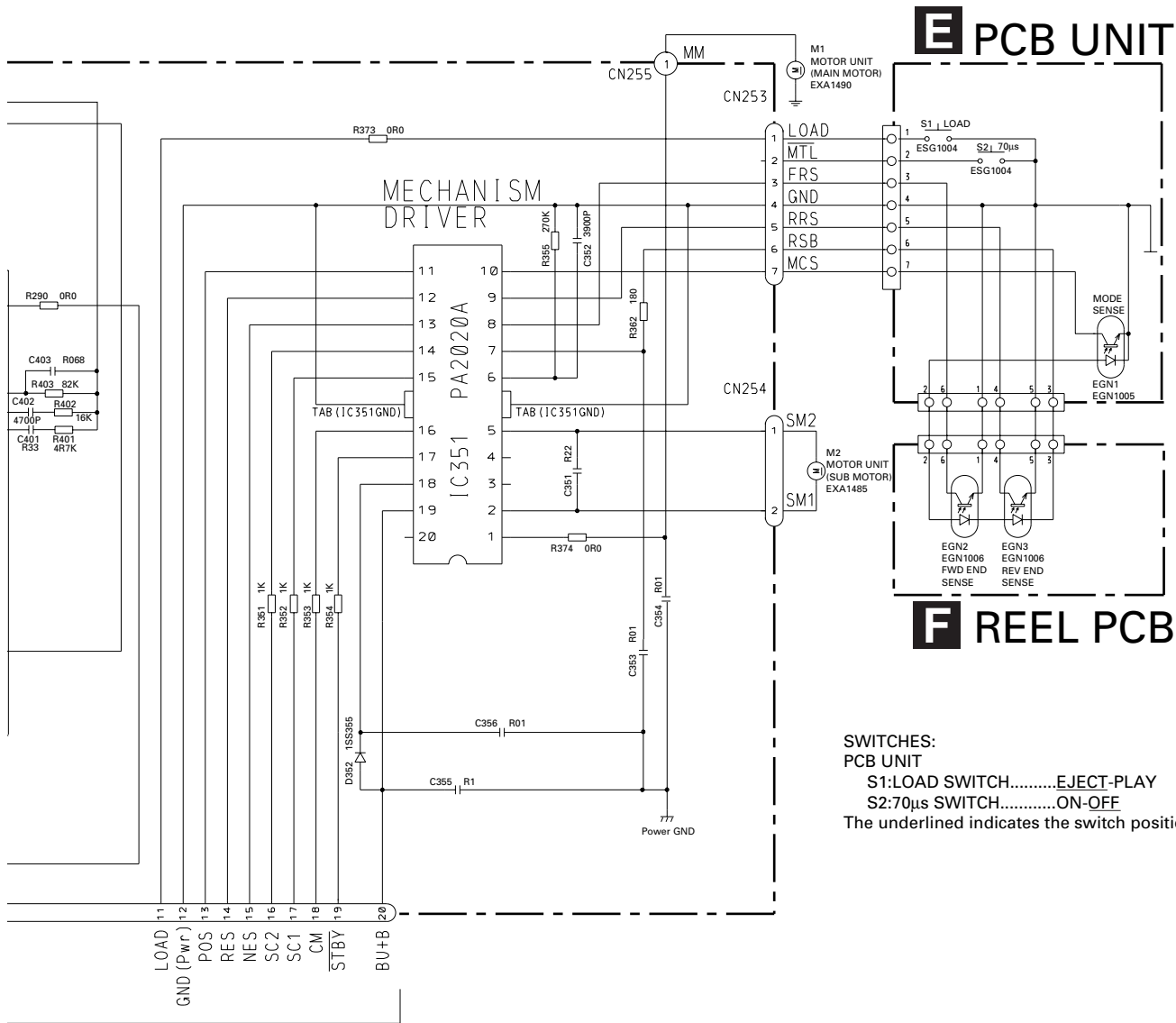

4. PCB CONNECTION DIAGRAM

4.1 TUNER AMP UNIT

NOTE FOR PCB DIAGRAMS

1. The parts mounted on this PCB include all necessary parts for several destination.

For further information for respective destinations, be sure to check with the schematic diagram.

2. Viewpoint of PCB diagrams

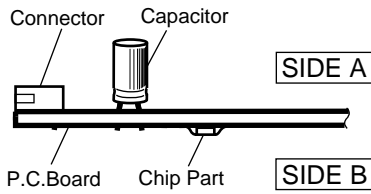

A TUNER AMP UNIT

IC. Q	ADJ
Q951	Q806
Q807	IC802
	Q809
	Q808
	Q953
Q804	Q805
	Q952
	Q802
	Q610
Q404	Q607
Q955	Q403
	Q956
IC602	IC601
Q957	
	Q751
	IC401
	IC201
Q301	Q205
	IC301
	Q604
	Q605
	Q606
	IC751
	Q302
	Q961
	IC601
	Q707
Q810	IC801
Q703	Q702
	Q704
	IC604
	Q609
	IC701

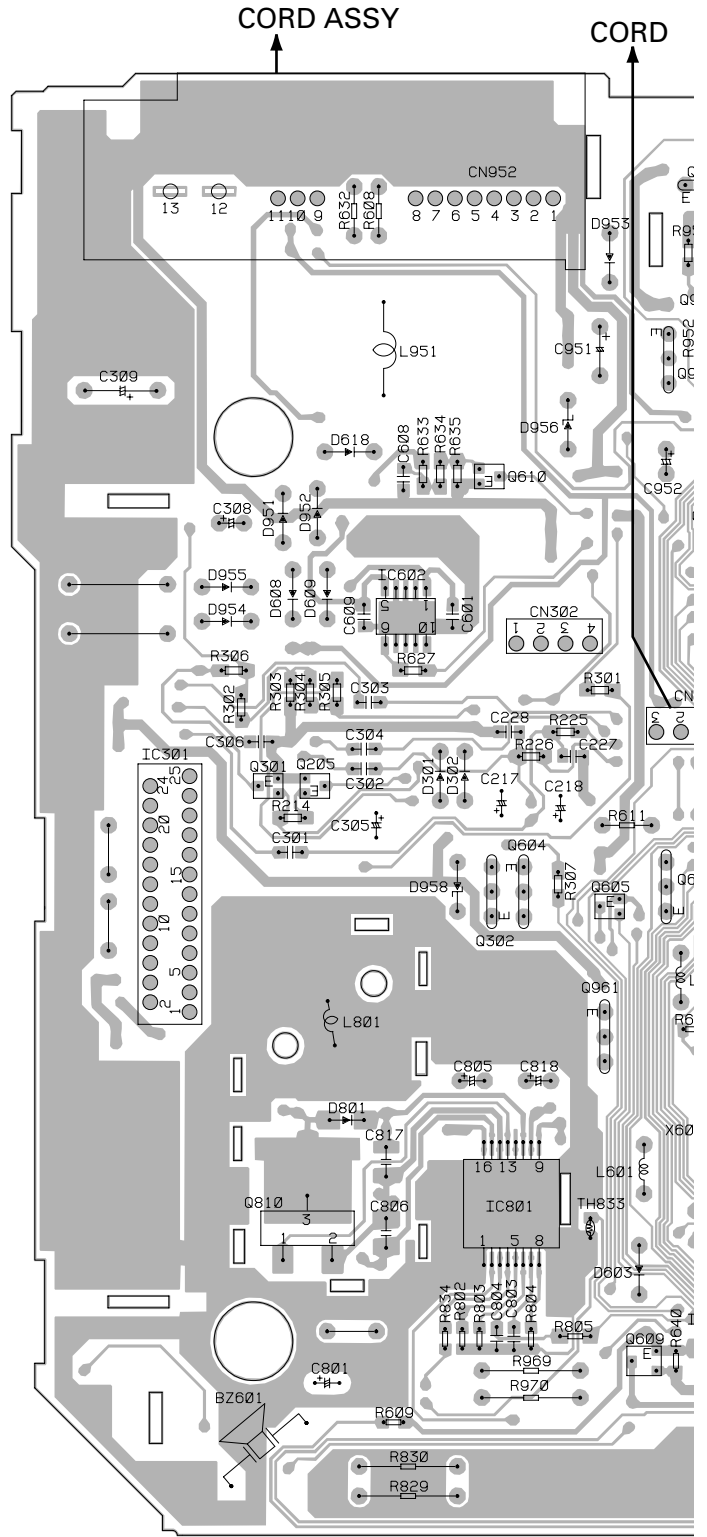

SIDE A

ORD

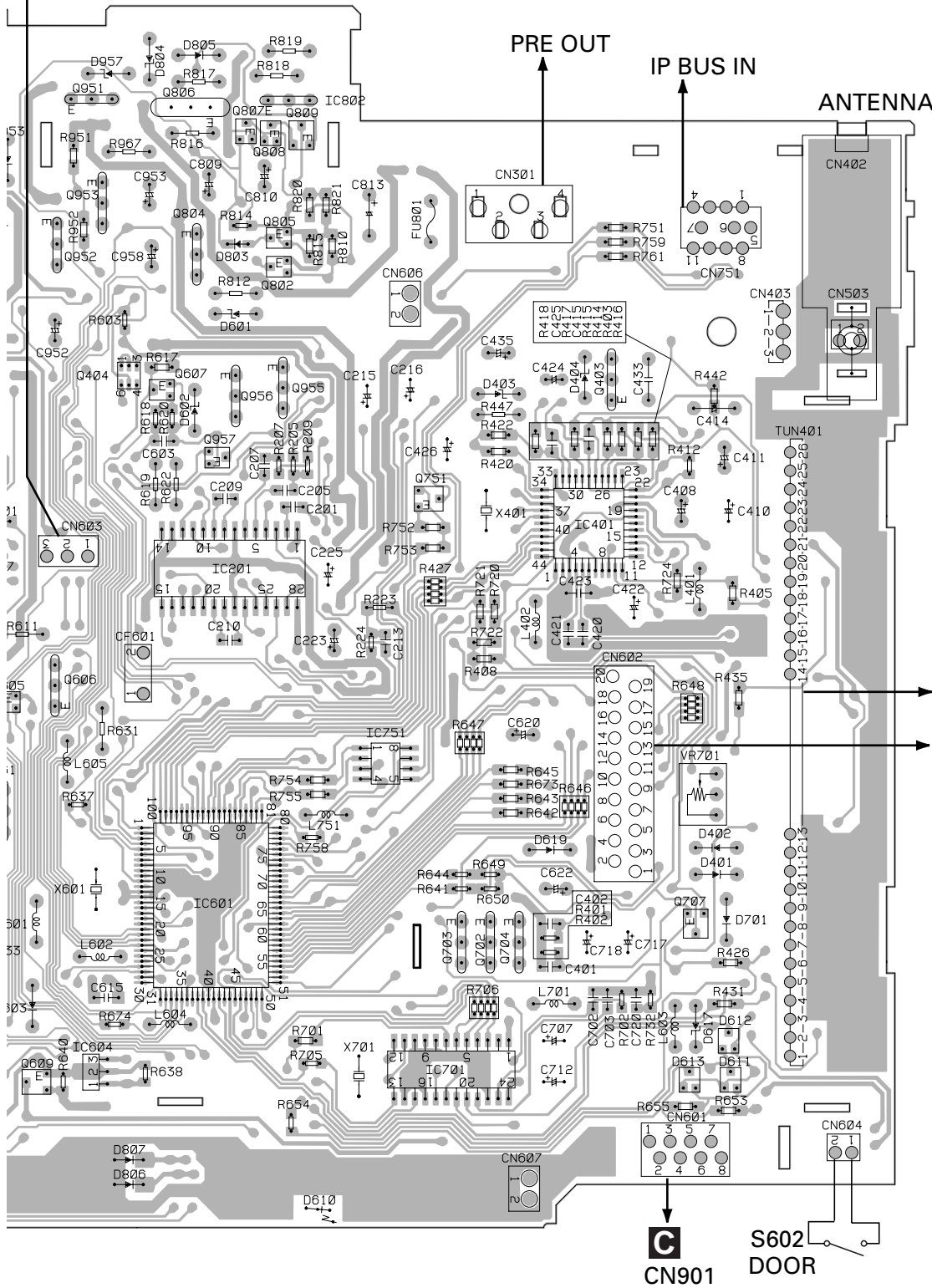

B
D
CN251

C
CN901
S602 DOOR

A

A

A TUNER AMP UNIT

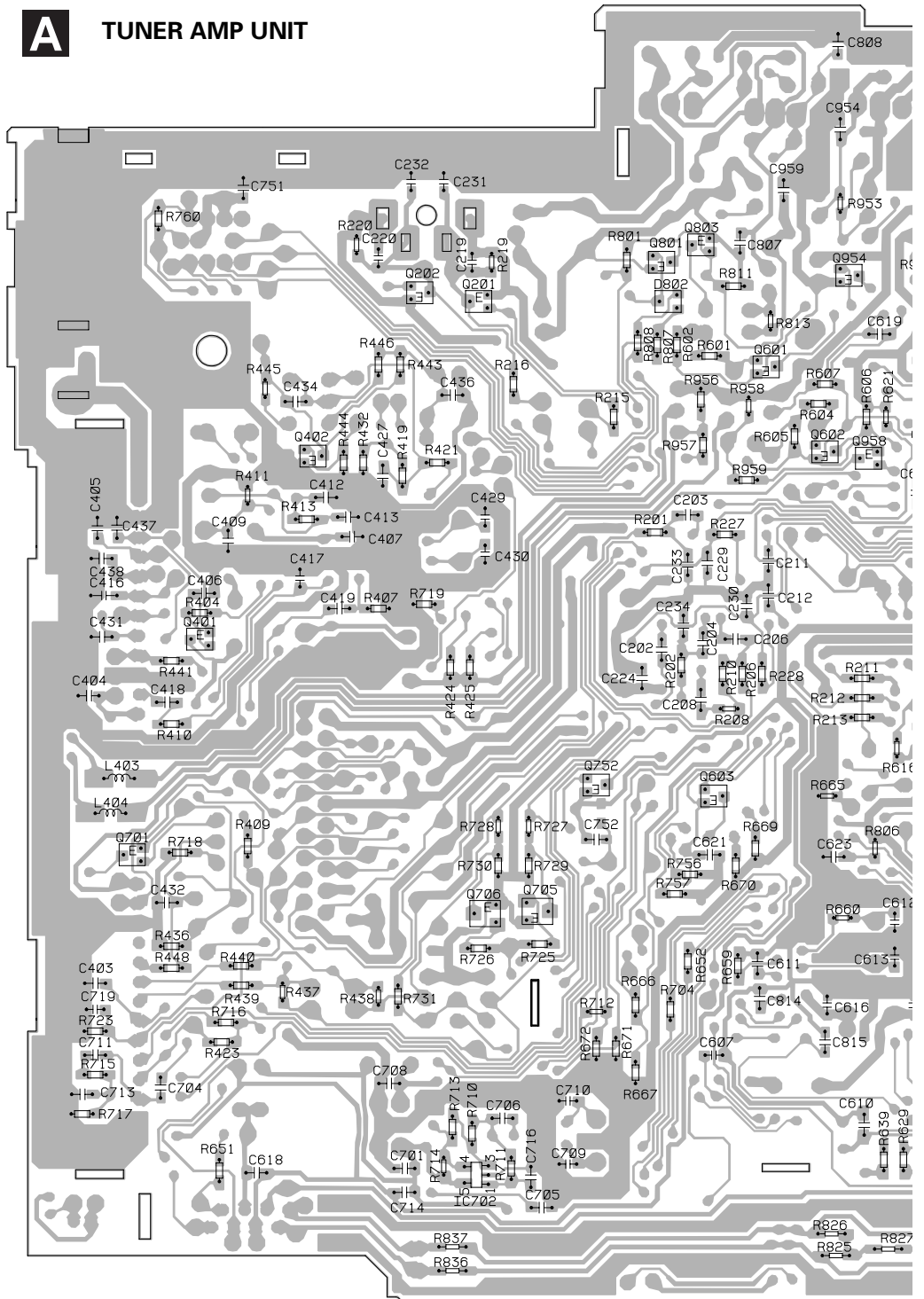

B

C

D

IC: Q

SIDE B

A

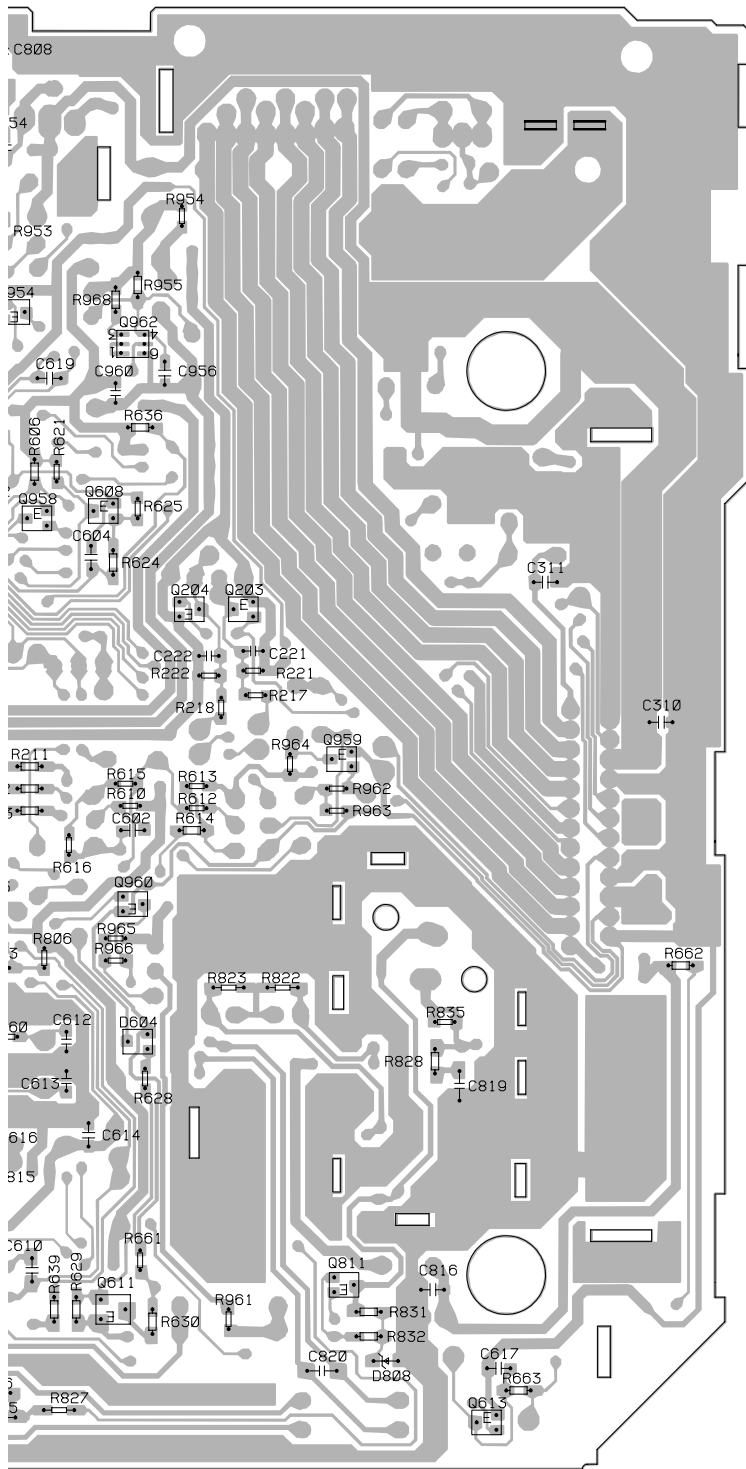

Q805
 Q801 Q954
 Q202
 Q201 Q962

Q601

Q402 Q602
 Q958 Q608

Q204
 Q205

Q401
 Q959

Q752 Q603
 Q960

Q701

Q706 Q705

Q811
 Q611

IC702
 Q613

B

C

D

A

4.2 KEYBOARD UNIT

SIDE A

KEYBOARD UNIT

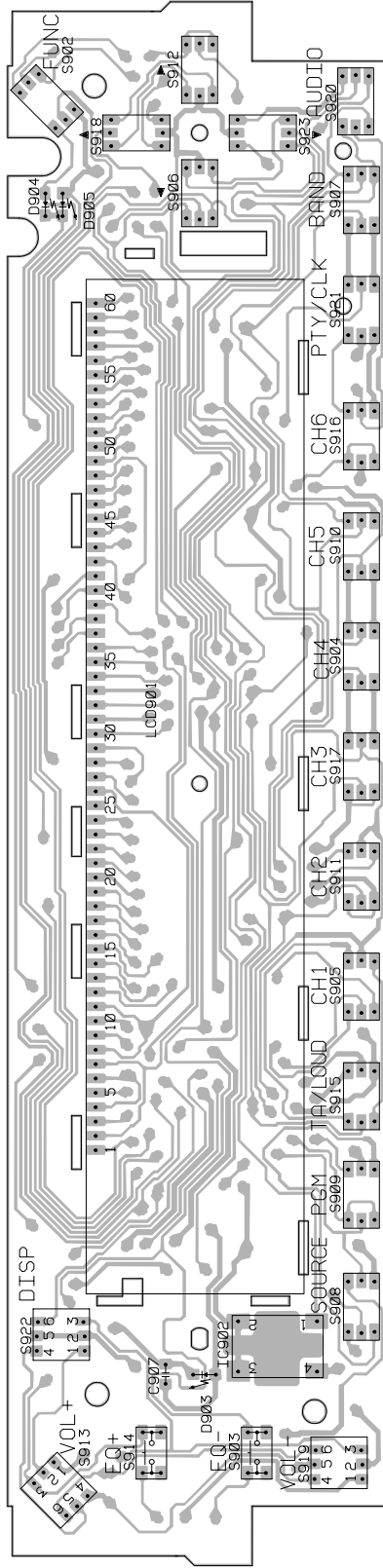

IC-0

0902



C KEYBOARD UNIT

IC: Q
 Q905
 Q901
 Q904
 Q903
 Q902
 TC901

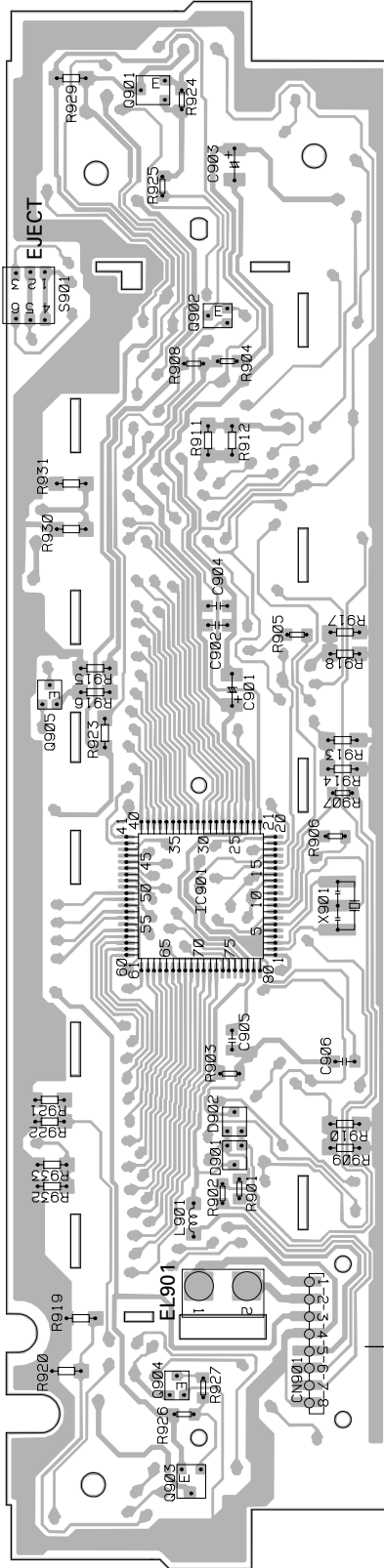

SIDE B

A CN601

A
 B
 C
 D

4.3 FM/AM TUNER UNIT

SIDE A

B FM/AM TUNER UNIT

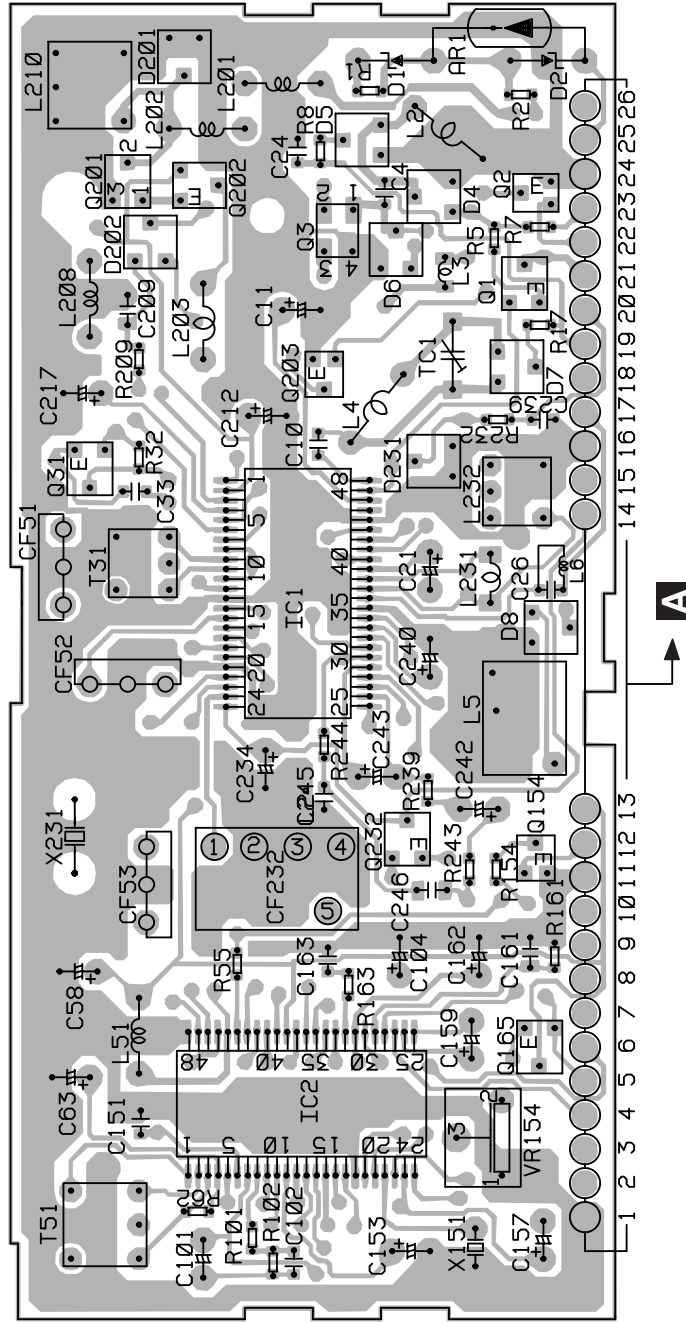

IC, Q	ADJ
Q31	T51
Q201	T31
Q202	L4
Q203 Q3	L2
IC2 IC1	TC1
Q232	L5
Q1	VR154
Q165 Q2	
Q154	

SIDE B

B FM/AM TUNER UNIT

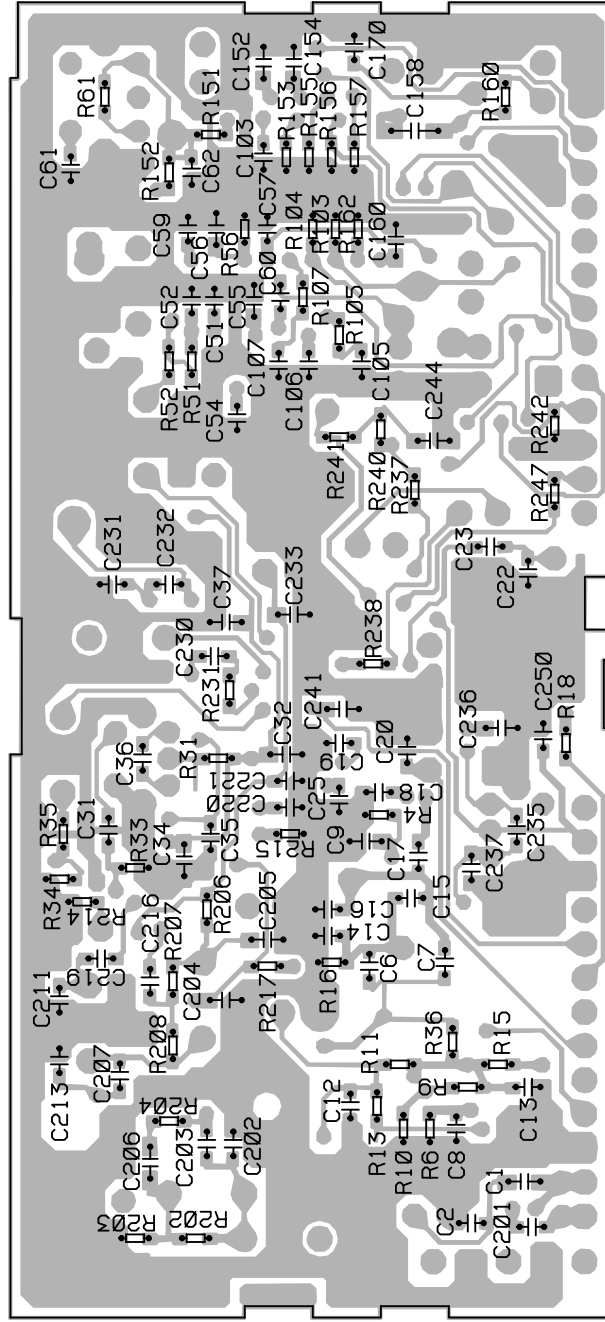

4.4 CASSETTE MECHANISM MODULE

D DECK UNIT

SIDE A

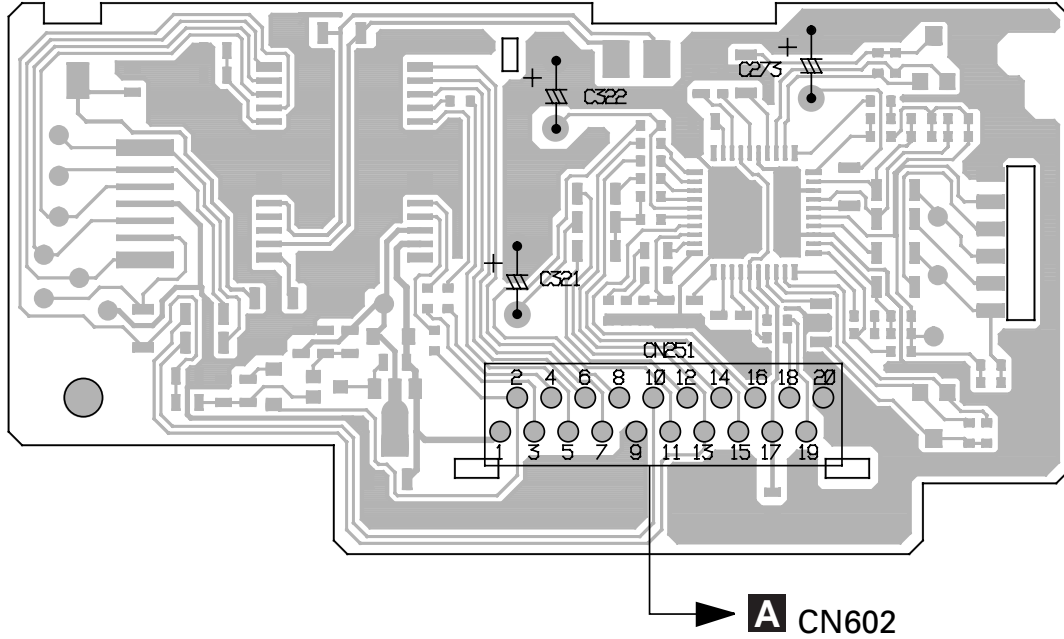

D DECK UNIT

SIDE B

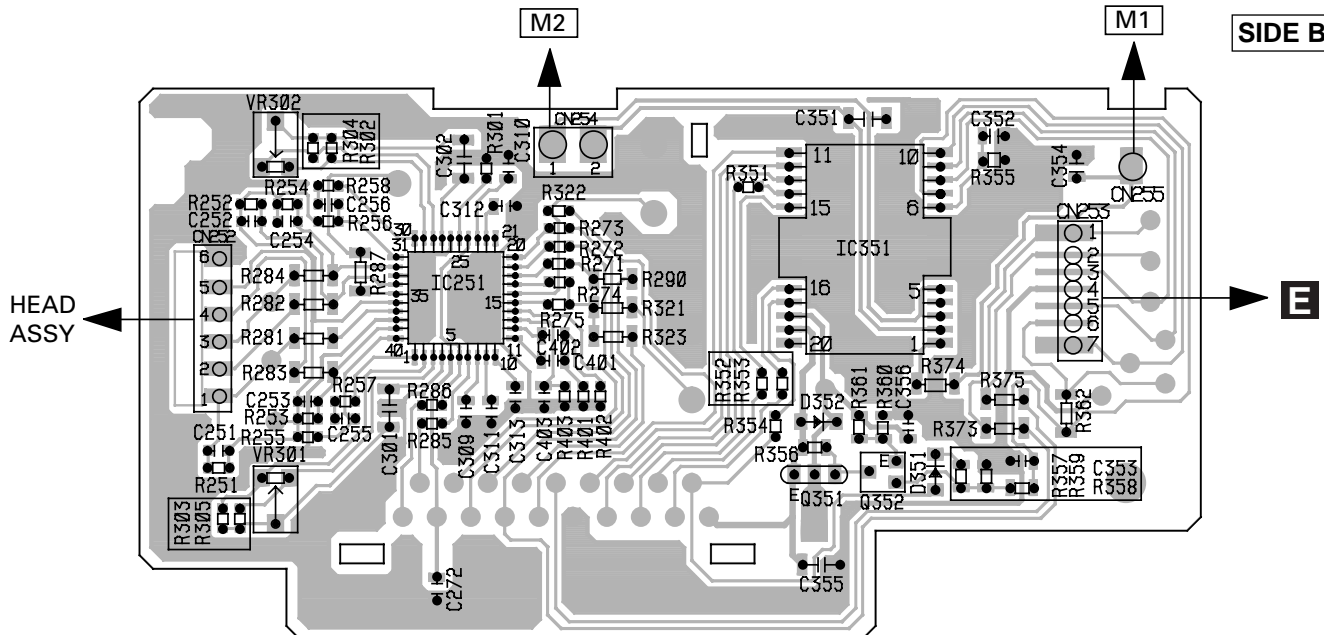

D

E PCB UNIT

SIDE A

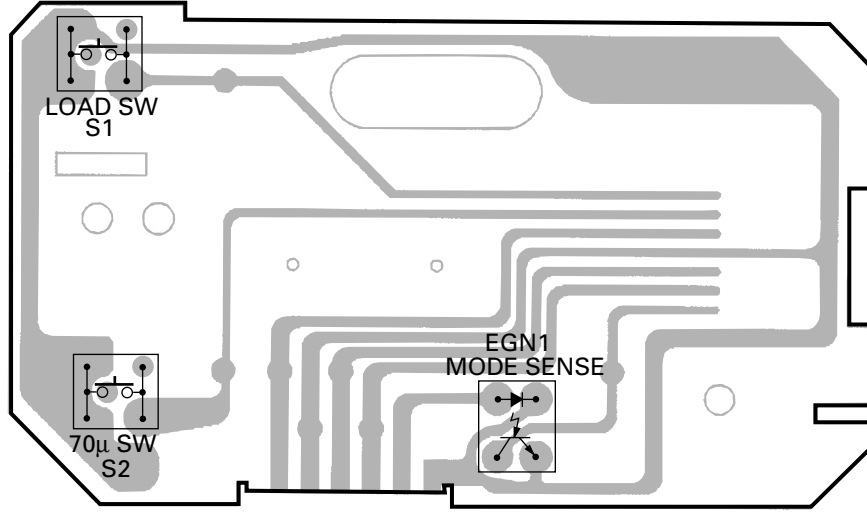

E PCB UNIT

SIDE B

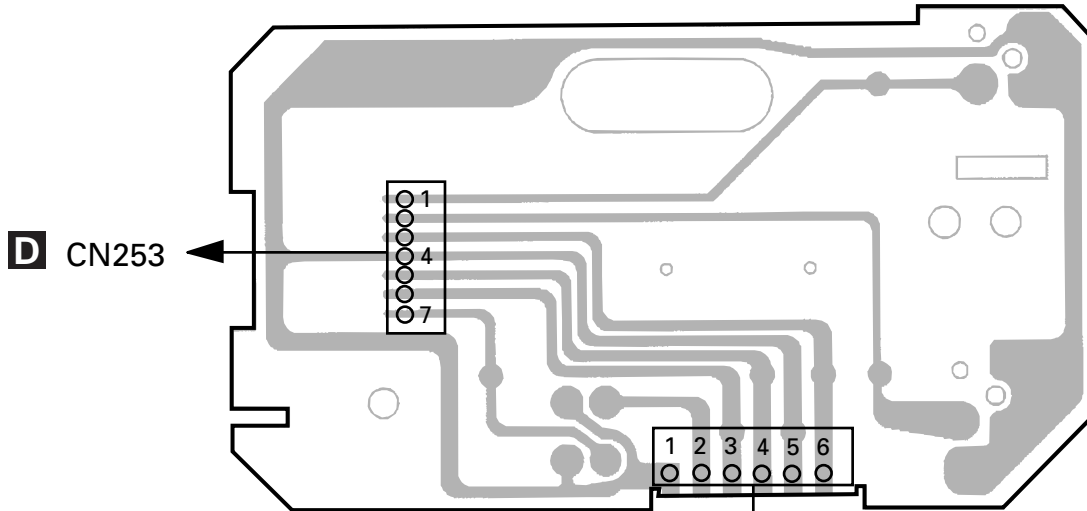

F REEL PCB

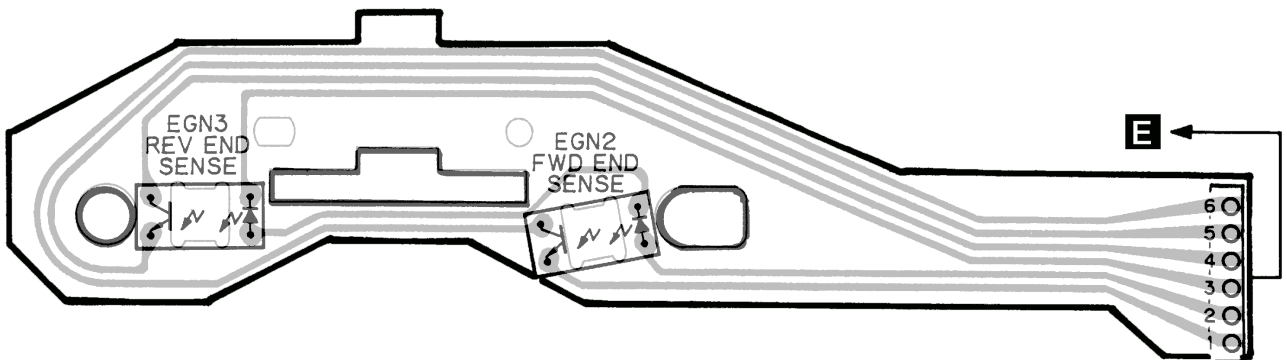

5. ELECTRICAL PARTS LIST

NOTE:

- Parts whose parts numbers are omitted are subject to being not supplied.
- The part numbers shown below indicate chip components.

Chip Resistor

RS1/○S○○○○J,RS1/○○S○○○○J

Chip Capacitor (except for CQS.....)

CKS....., CCS....., CSZS.....

====Circuit Symbol and No.====Part Name	Part No.	====Circuit Symbol and No.====Part Name	Part No.
B Unit Number : CWE1466 Unit Name : FM/AM Tuner Unit		R 15	RS1/16S271J
		R 16	RS1/16S104J
		R 17	RS1/16S332J
		R 18	RS1/16S332J
		R 31	RS1/16S470J
MISCELLANEOUS			
IC 1 IC	PA4023B		
IC 2 IC	PA4024A	R 32	RS1/16S822J
Q 1 Transistor	2SC2412K	R 33	RS1/16S822J
Q 2 Transistor	DTC124EU	R 34	RS1/16S331J
Q 3 FET	3SK263	R 35	RS1/16S331J
		R 51	RS1/16S271J
Q 31 Transistor	2SC2412K		
Q 154 Transistor	DTC124EU	R 52	RS1/16S560J
Q 165 Transistor	2SC2412K	R 55	RS1/16S102J
Q 201 FET	2SK932	R 56	RS1/16S823J
Q 202 Transistor	2SC2412K	R 61	RS1/16S392J
		R 62	RS1/16S393J
Q 203 Transistor	DTC124EU		
D 4 Diode	1SV250	R 101	RS1/16S272J
D 5 Diode	KV1410-F1	R 102	RS1/16S682J
D 7 Diode	KV1410-F1	R 103	RS1/16S333J
D 8 Diode	KV1410-F1	R 104	RS1/16S334J
		R 105	RS1/16S683J
D 201 Diode	MA157		
D 202 Diode	MA157	R 107	RS1/16S222J
D 231 Diode	SVC253	R 151	RS1/16S222J
L 2 Coil	CTC1133	R 152	RS1/16S393J
L 3 Inductor	LCTB2R2K2125	R 154	RS1/16S104J
		R 155	RS1/16S273J
L 4 Coil	CTC1133		
L 5 Coil	CTC1132	R 156	RS1/16S243J
L 6 Inductor	LCTBR15K1608	R 157	RS1/16S203J
L 51 Ferri-Inductor	LAU150K	R 160	RS1/16S222J
L 201 Ferri-Inductor	LAU4R7K	R 161	RS1/16S563J
		R 162	RS1/16S105J
L 202 Ferri-Inductor	LAU330K		
L 203 Inductor	CTF1287	R 163	RS1/16S222J
L 208 Inductor	LAU121K	R 202	RS1/16S223J
L 231 Inductor	LCTA3R3J3225	R 203	RS1/16S225J
T 31 Coil	CTE1116	R 204	RS1/16S103J
		R 206	RS1/16S220J
T 51 Coil	CTC1136		
TC 1 Trimmer	CCL1046	R 207	RS1/16S101J
CF 51 Ceramic Filter	CTF1442	R 208	RS1/16S102J
CF 52 Ceramic Filter	CTF1442	R 209	RS1/16S471J
CF 53 Ceramic Filter	CTF1442	R 214	RS1/16S822J
		R 215	RS1/16S822J
CF 232 Ceramic Filter	CTF1348		
X 151 Radiator 918.5Hz	CSS1365	R 217	RS1/16S102J
X 231 Crystal Resonator 10.26MHz	CSS1111	R 231	RS1/16S272J
VR 154 Semi-fixed 150kΩ(B)	CCP1213	R 232	RS1/16S473J
AR 1	DSP-201M	R 237	RS1/16S103J
		R 238	RS1/16S104J
RESISTORS		R 239	RS1/16S104J
R 1	RS1/16S0R0J	R 240	RS1/16S332J
R 4	RS1/16S154J	R 241	RS1/16S202J
R 5	RS1/16S391J	R 243	RS1/16S123J
R 6	RS1/16S223J	R 244	RS1/16S103J
R 7	RS1/16S123J	R 247	RS1/16S123J
R 8	RS1/16S332J		
R 9	RS1/16S473J		
R 10	RS1/16S223J		
R 11	RS1/16S124J		
R 13	RS1/16S563J		

====Circuit Symbol and No.====Part Name	Part No.	====Circuit Symbol and No.====Part Name	Part No.
CAPACITORS			
C 1	CCSQCH6R0D50	C 213	CKSRYP103K25
C 2	CCSRCK2R0C50	C 216	CCSRCH101J50
C 4	CCSRCH820J50	C 217	CEJA1R5M50
C 6	CCSRCH820J50	C 219	CCSRCH471J50
C 8	CKSRYP103K25	C 220	CKSRYP103K25
C 9	CKSQYB104K16	C 230	CKSRYP103K25
C 10	CCSRCKR50C50	C 231	CCSRCH330J50
C 11	CEJA1R0M50	C 232	CCSRCH150J50
C 13	CKSRYP222K50	C 233	CKSQYB104K16
C 14	CCSRCH220J50	C 234	CEJA330M10
C 16	CCSRCH8R0D50	C 235	CKSRYP332K50
C 17	CKSRYP222K50	C 236	CKSQYB473K16
C 18	CKSRYP103K25	C 237	CCSRCH120J50
C 19	CKSRYP222K50	C 239	CKSRYP472K50
C 20	CKSRYP222K50	C 240	CEJAR47M50
C 21	CEJA100M16	C 241	CKSQYB104K16
C 22	CCSRTH9R0D50	C 242	CEJAR47M50
C 23	CCSRTH120J50	C 243	CEJAR33M50
C 24	CCSRCH471J50	C 244	CKSQYB473K16
C 25	CKSRYP103K25	C 245	CKSRYP123K25
C 31	CKSRYP103K25	C 246	CKSQYB473K16
C 32	CKSQYB472K50	C 250	CCSRCH471J50
C 33	CCSRCH5R0C50	A Unit Number : CWM6062(KEH-P7800R)	
C 34	CKSQYB104K16	Unit Name : Tuner Amp Unit	
C 36	CCSRRH201J50	MISCELLANEOUS	
C 51	CKSRYP223K25	IC 201	IC PML003AM
C 52	CKSRYP103K25	IC 301	IC PAL005A
C 54	CCSRCH470J50	IC 401	IC PM2007A
C 55	CKSQYB223K25	IC 601	IC PD4975B
C 56	CKSQYB104K16	IC 604	IC S-80734ANDYI
C 57	CKSRYP472K50	IC 701	IC PM4006B
C 58	CEJA330M10	IC 702	IC TA75S393F
C 59	CKSRYP103K25	IC 751	IC HA12187FP
C 61	CCSRCH270J50	IC 801	IC PML005A
C 62	CKSRYP103K25	Q 201	Transistor DTC143TU
C 63	CEJAR15M50	Q 202	Transistor DTC143TU
C 101	CEJANP100M10	Q 205	Transistor DTA124EU
C 102	CKSRYP182K50	Q 301	Transistor DTC124EU
C 103	CKSRYP682K25	Q 302	Transistor 2SC1740S
C 104	CEJA2R2M50	Q 401	Transistor 2SC4081
C 105	CKSRYP103K25	Q 404	Transistor IMD2A
C 106	CCSRCH151J50	Q 601	Transistor 2SC4081
C 107	CKSRYP103K25	Q 602	Transistor 2SC4081
C 151	CKSRYP472K50	Q 603	Transistor DTA114EU
C 152	CKSQYB104K16	Q 604	Transistor 2SA933S
C 153	CEJA3R3M50	Q 605	Transistor DTC124EU
C 154	CKSQYB104K16	Q 606	Transistor 2SC1740S
C 157	CEJA3R3M50	Q 609	Transistor 2SA1037K
C 158	CKSYB474K16	Q 610	Transistor 2SC4081
C 159	CEJA220M6R3	Q 611	Transistor 2SA1037K
C 160	CKSQYB104K16	Q 613	Transistor DTC124EU
C 161	CKSQYB104K16	Q 701	Transistor DTC143TU
C 162	CEJA3R3M50	Q 702	Transistor DTC114ES
C 163	CKSRYP102K50	Q 703	Transistor DTC143TS
C 170	CCSRCH100D50	Q 704	Transistor DTC143TS
C 201	CCSRCH471J50	Q 705	Transistor 2SD1757K
C 202	CCSRCH100D50	Q 706	Transistor 2SD1757K
C 203	CKSRYP332K50	Q 707	Transistor 2SC2412K
C 204	CKSQYB473K16	Q 751	Transistor 2SA1037K
C 205	CKSQYB473K16	Q 752	Transistor DTC114EU
C 206	CKSQYB104K16	Q 801	Transistor 2SC4081
C 207	CCSRCH560J50	Q 810	FET 2SK2356Z
C 209	CKSQYB104K16	Q 811	Transistor 2SC4081
C 211	CCSRCH101J50	Q 951	Transistor 2SD2396
C 212	CEJA470M6R3	Q 952	Transistor 2SD2037

KEH-P7800R,P6800R

====Circuit Symbol and No.===Part Name	Part No.	====Circuit Symbol and No.===Part Name	Part No.
Q 953 Transistor	2SA933S	R 208	RS1/10S102J
Q 954 Transistor	DTC114EU	R 209	RS1/10S223J
Q 955 Transistor	2SA1674	R 210	RS1/10S223J
Q 956 Transistor	2SA1048	R 211	RS1/10S0R0J
Q 957 Transistor	DTC114TU	R 212	RS1/10S222J
Q 958 Transistor	DTC114TU	R 213	RS1/10S222J
Q 959 Transistor	2SC4081	R 214	RS1/10S562J
Q 960 Transistor	DTC114TU	R 215	RS1/10S821J
Q 961 Transistor	2SB1243	R 216	RS1/10S821J
Q 962 Transistor	IMD2A	R 219	RS1/10S473J
D 301 Diode	1SS133	R 220	RS1/10S473J
D 302 Diode	1SS133	R 223	RS1/8S103J
D 401 Diode	1SS133	R 224	RS1/10S102J
D 601 Diode	HZS7L(C2)	R 225	RS1/10S0R0J
D 602 Diode	HZS7L(A1)	R 226	RS1/10S0R0J
D 603 Diode	1SS133	R 227	RS1/10S0R0J
D 604 Diode	DAN202U	R 228	RS1/10S0R0J
D 610 LED	BR4361F	R 301	RS1/10S103J
D 611 Diode Array	DA204U	R 302	RS1/10S221J
D 612 Diode Array	DA204U	R 303	RS1/10S153J
D 613 Diode Array	DA204U	R 304	RS1/10S103J
D 617 Diode	HZS7L(A1)	R 305	RS1/10S152J
D 618 Diode	ERA15-02VH	R 306	RS1/10S101J
D 619 Diode	1SS133	R 307	RS1/10S223J
D 701 Diode	1SS133	R 401	RS1/10S272J
D 801 Diode	U1JU44	R 402	RS1/10S272J
D 802 Diode	DAN202U	R 403	RS1/10S102J
D 806 Diode	U1JU44	R 404	RS1/10S222J
D 807 Diode	U1JU44	R 405	RS1/10S222J
D 808 Diode	MA8075(M)	R 407	RS1/10S0R0J
D 951 Diode	ERA15-02VH	R 408	RS1/10S562J
D 952 Diode	ERA15-02VH	R 409	RS1/10S222J
D 953 Diode	ERA15-02VH	R 410	RS1/10S102J
D 954 Diode	ERA15-02VH	R 411	RS1/10S682J
D 955 Diode	ERA15-02VH	R 412	RS1/10S472J
D 956 Diode	HZS6L(B2)	R 413	RS1/10S222J
D 957 Diode	HZS9L(B3)	R 414	RS1/10S682J
D 958 Diode	HZS9L(A2)	R 415	RS1/10S472J
L 401 Ferri-Inductor	LAU2R2K	R 416	RS1/10S561J
L 402 Ferri-Inductor	LAU2R2K	R 417	RS1/10S103J
L 403 Inductor	LCTA100J3225	R 418	RS1/10S152J
L 404 Inductor	LCTA100J3225	R 419	RS1/10S222J
L 601 Ferri-Inductor	LAU2R2K	R 420	RS1/10S392J
L 602 Ferri-Inductor	LAU101K	R 421	RS1/10S272J
L 603 Ferri-Inductor	LAU2R2K	R 422	RS1/10S392J
L 604 Ferri-Inductor	LAU2R2K	R 423	RS1/10S473J
L 605 Ferri-Inductor	LAU2R2K	R 424	RS1/10S473J
L 701 Ferri-Inductor	LAU101K	R 425	RS1/10S222J
L 751 Ferri-Inductor	LAU2R2K	R 426	RS1/10S473J
L 801 Coil	CTH1227	R 427	RA4C102J
L 951 Coil 600μH	CTH1219	R 431	RS1/10S472J
TH 833 Thermistor	CCX1042	R 435	RS1/10S103J
CF 601 Filter	CTF1071	R 436	RS1/10S393J
X 401 Crystal Resonator 7.200MHz	CSS1379	R 439	RS1/10S0R0J
X 601 Radiator 12.58291MHz	CSS1402	R 440	RS1/10S0R0J
X 701 Crystal Resonator 4.332MHz	CSS1056	R 441	RS1/10S680J
VR 701 Semi-fixed 22kΩ(B) FM/AM Tuner Unit	CCP1321	R 448	RS1/10S102J
BZ 601 Buzzer	CWE1466	R 601	RS1/10S473J
	CPV1011	R 602	RS1/10S473J
		R 603	RS1/10S104J
RESISTORS		R 604	RS1/10S223J
R 201	RS1/10S102J	R 605	RS1/10S473J
R 202	RS1/10S102J	R 606	RS1/10S473J
R 205	RS1/10S821J	R 607	RS1/10S472J
R 206	RS1/10S821J	R 608	RD1/4PU102J
R 207	RS1/10S102J		

====Circuit Symbol and No.====Part Name	Part No.	====Circuit Symbol and No.====Part Name	Part No.
R 609	RS1/10S751J	R 729	RS1/10S223J
R 610	RS1/10S473J	R 730	RS1/10S223J
R 611	RD1/4PU102J	R 731	RS1/10S103J
R 612	RS1/10S103J	R 732	RS1/10S224J
R 613	RS1/10S223J	R 751	RS1/10S222J
R 614	RS1/10S223J	R 752	RS1/10S223J
R 615	RS1/10S223J	R 753	RS1/10S472J
R 616	RS1/10S272J	R 754	RS1/10S102J
R 628	RS1/10S472J	R 755	RS1/10S102J
R 629	RS1/10S472J	R 756	RS1/10S473J
R 630	RS1/10S102J	R 757	RS1/10S473J
R 631	RD1/4PU153J	R 758	RS1/10S102J
R 632	RD1/4PU102J	R 759	RS1/10S101J
R 633	RS1/10S103J	R 760	RS1/10S620J
R 634	RS1/10S103J	R 761	RS1/10S101J
R 635	RS1/10S473J	R 801	RS1/10S103J
R 636	RS1/10S473J	R 802	RS1/10S562J
R 637	RS1/10S102J	R 803	RS1/10S123J
R 638	RS1/10S822J	R 804	RS1/10S912J
R 639	RS1/10S222J	R 805	RS1/8S472J
R 640	RS1/10S223J	R 806	RS1/10S473J
R 641	RS1/10S222J	R 807	RS1/10S224J
R 642	RS1/10S103J	R 808	RS1/10S224J
R 643	RS1/10S222J	R 810	RS1/10S204J
R 644	RS1/10S222J	R 822	RS1/8S225J
R 645	RS1/10S103J	R 823	RS1/8S225J
R 646	RA4C222J	R 825	RS1/8S474J
R 647	RA4C222J	R 826	RS1/8S474J
R 648	RA4C473J	R 827	RS1/8S105J
R 649	RS1/10S103J	R 829	RD1/2PM182J
R 650	RS1/10S392J	R 830	RD1/2PM182J
R 651	RS1/10S472J	R 831	RS1/10S152J
R 652	RS1/10S472J	R 832	RS1/10S103J
R 653	RS1/10S222J	R 834	RS1/10S103J
R 654	RS1/10S222J	R 836	RS1/8S391J
R 655	RS1/10S473J	R 837	RS1/8S391J
R 659	RS1/10S473J	R 951	RS1/10S473J
R 660	RS1/10S102J	R 952	RS1/10S102J
R 661	RS1/10S473J	R 953	RS1/10S102J
R 662	RS1/10S152J	R 954	RS1/10S101J
R 663	RS1/10S152J	R 955	RS1/10S103J
R 665	RS1/10S473J	R 956	RS1/10S473J
R 666	RS1/10S104J	R 957	RS1/10S102J
R 669	RS1/10S473J	R 958	RS1/10S473J
R 673	RS1/10S222J	R 959	RS1/10S102J
R 674	RS1/10S222J	R 961	RS1/10S1R0J
R 701	RS1/10S102J	R 962	RS1/10S103J
R 702	RS1/10S333J	R 963	RS1/10S223J
R 704	RS1/10S102J	R 964	RS1/10S472J
R 705	RS1/10S102J	R 965	RS1/10S473J
R 706	RA4C102J	R 966	RS1/10S272J
R 710	RS1/10S222J	R 967	RD1/4PU152J
R 711	RS1/10S222J	R 968	RS1/10S152J
R 712	RS1/10S681J	R 969	RD1/2PM390J
R 713	RS1/10S684J	R 970	RD1/2PM390J
R 714	RS1/10S562J	CAPACITORS	
R 715	RS1/10S562J	C 201	CKSQYB224K16
R 716	RS1/10S104J	C 202	CKSQYB224K16
R 717	RS1/10S104J	C 203	CKSQYB224K16
R 718	RS1/10S103J	C 204	CKSQYB224K16
R 719	RS1/10S473J	C 205	CKSQYB105K16
R 720	RS1/10S102J	C 206	CKSQYB105K16
R 721	RS1/10S102J	C 207	CKSQYB105K16
R 722	RS1/10S562J	C 208	CKSQYB105K16
R 723	RS1/10S105J	C 209	CKSQYB105K16
R 724	RS1/10S0R0J	C 210	CKSQYB105K16
R 725	RS1/10S224J		
R 726	RS1/10S224J		
R 727	RS1/10S222J		
R 728	RS1/10S222J		

KEH-P7800R,P6800R

====Circuit Symbol and No.====Part Name	Part No.	====Circuit Symbol and No.====Part Name	Part No.
C 211	CKSQYB153K50	C 622	CEJA220M10
C 212	CKSQYB153K50	C 701	CKSQYF104Z25
C 213	CKSQYB473K25	C 702	CKSQYB222K50
C 215	CEJA2R2M50	C 703	CKSQYB104K25
C 216	CEJA2R2M50	C 704	CKSQYB105K10
C 219	CCSQSL221J50	C 705	CKSQYB104K25
C 220	CCSQSL221J50	C 706	CKSQYB472K50
C 223	CEJA470M10	C 707	CEJA4R7M35
C 224	CKSQYF104Z25	C 708	CKSQYB104K25
C 225	CEJA100M16	C 709	CCSQCH220J50
C 233	CKSQYB332K50	C 710	CCSQCH220J50
C 234	CKSQYB332K50	C 711	CKSQYB104K25
C 301	CKSQYB224K16	C 712	CEJA4R7M35
C 302	CKSQYB224K16	C 713	CKSQYB223K50
C 303	CKSQYB224K16	C 714	CCSQSL101J50
C 304	CKSQYB224K16	C 716	CKSQYB103K50
C 305	CEJA100M16	C 717	CEJA2R2M50
C 306	CKSQYB105K16	C 718	CEJA2R2M50
C 308	CEJA330M10	C 719	CKSQYB471K50
C 309	4700μF/16V CCH1178	C 720	CKSQYB223K50
C 310	CKSQYB104K25	C 751	CKSQYB104K25
C 311	CKSQYB103K50	C 752	CKSQYB102K50
C 401	CKSQYB223K50	C 801	CEJA100M16
C 402	CKSQYB223K50	C 803	CKSQYB222K50
C 403	CKSQYB223K50	C 805	2.2μF/250V CCH1327
C 404	CKSQYB273K50	C 806	CCG1089
C 406	CKSQYB223K50	C 814	CCSQSL101J50
C 407	CKSQYB102K50	C 815	CCSQSL101J50
C 408	CEJA220M16	C 816	CKSQYB103K50
C 409	CKSQYB103K50	C 817	CCG1091
C 410	CEJA220M6R3	C 818	2.2μF/250V CCH1327
C 411	CEJA220M10	C 820	CCG1095
C 412	CKSQYB103K50	C 951	470μF/16V CCH1183
C 413	CKSQYB103K50	C 952	CEJA470M10
C 414	4.7μF/16V CCH1250	C 953	CEJA101M10
C 415	CKSQYB103K50	C 954	CKSQYB103K50
C 416	CKLSR473K16	C 956	CKSQYB103K50
C 417	CCSQSL101J50	C 958	CEJA101M10
C 418	CKSQYB103K50	C 959	CCSQSL101J50
C 420	CKSQYB103K50		
C 421	CKSQYB103K50		
C 422	CEJA220M6R3		
C 423	CKSYB473K25		
C 424	4.7μF/16V CCH1250		
C 425	CKSQYB103K50		
C 426	CEJAR47M50		
C 427	CKSQYB103K50		
C 429	CCSQCH150J50		
C 430	CCSQCH150J50		
C 431	CKSQYB103K50		
C 432	CKSQYB223K50		
C 437	CCSQSL101J50		
C 602	CKSQYB103K50		
C 608	CKSQYF105Z25		
C 610	CKSQYB225K10		
C 611	CKSQYB104K25		
C 612	CCSQCH200J50		
C 613	CCSQCH200J50		
C 614	CKSQYB103K50		
C 615	CSZS4R7M16		
C 616	CCSQSL101J50		
C 617	CKSQYB103K50		
C 619	CKSQYB102K50		
C 620	CEJA100M16		
C 621	CCSQSL101J50		

A Unit Number : CWM6151(KEH-P6800R)
Unit Name : Tuner Amp Unit

MISCELLANEOUS

IC 201	IC	PML003AM
IC 301	IC	PAL005A
IC 401	IC	PM2007A
IC 601	IC	PD4975B
IC 604	IC	S-80734ANDYI
IC 701	IC	PM4006B
IC 702	IC	TA75S393F
IC 751	IC	HA12187FP
IC 801	IC	PML005A
Q 201	Transistor	DTC143TU
Q 202	Transistor	DTC143TU
Q 205	Transistor	DTA124EU
Q 301	Transistor	DTC124EU
Q 302	Transistor	2SC1740S
Q 401	Transistor	2SC4081
Q 404	Transistor	IMD2A
Q 601	Transistor	2SC4081
Q 602	Transistor	2SC4081
Q 603	Transistor	DTA114EU
Q 609	Transistor	2SA1037K
Q 610	Transistor	2SC4081
Q 611	Transistor	2SA1037K
Q 613	Transistor	DTC124EU
Q 701	Transistor	DTC143TU
Q 702	Transistor	DTC114ES

====Circuit Symbol and No.====Part Name	Part No.	====Circuit Symbol and No.====Part Name	Part No.
Q 703	Transistor	DTC143TS	
Q 704	Transistor	DTC143TS	
Q 705	Transistor	2SD1757K	R 201
Q 706	Transistor	2SD1757K	R 202
Q 707	Transistor	2SC2412K	R 205
			R 206
			R 207
Q 751	Transistor	2SA1037K	
Q 752	Transistor	DTC114EU	
Q 801	Transistor	2SC4081	R 208
Q 810	FET	2SK2356Z	R 209
Q 811	Transistor	2SC4081	R 210
			R 211
			R 212
Q 951	Transistor	2SD2396	
Q 952	Transistor	2SD2037	
Q 953	Transistor	2SA933S	R 213
Q 954	Transistor	DTC114EU	R 214
Q 955	Transistor	2SA1674	R 215
			R 216
			R 219
Q 956	Transistor	2SA1048	
Q 957	Transistor	DTC114TU	
Q 958	Transistor	DTC114TU	R 220
Q 959	Transistor	2SC4081	R 225
Q 960	Transistor	DTC114TU	R 226
			R 227
			R 228
Q 961	Transistor	2SB1243	
Q 962	Transistor	IMD2A	
D 301	Diode	1SS133	R 301
D 302	Diode	1SS133	R 302
D 401	Diode	1SS133	R 303
			R 304
			R 305
D 601	Diode	HZS7L(C2)	
D 602	Diode	HZS7L(A1)	
D 603	Diode	1SS133	R 306
D 604	Diode	DAN202U	R 307
D 611	Diode Array	DA204U	R 401
			R 402
			R 403
D 612	Diode Array	DA204U	
D 613	Diode Array	DA204U	
D 617	Diode	HZS7L(A1)	R 404
D 618	Diode	ERA15-02VH	R 405
D 619	Diode	1SS133	R 407
			R 408
			R 409
D 701	Diode	1SS133	
D 801	Diode	U1JU44	
D 802	Diode	DAN202U	R 410
D 806	Diode	U1JU44	R 411
D 807	Diode	U1JU44	R 412
			R 413
			R 414
D 808	Diode	MA8075(M)	
D 951	Diode	ERA15-02VH	
D 952	Diode	ERA15-02VH	R 415
D 953	Diode	ERA15-02VH	R 416
D 954	Diode	ERA15-02VH	R 417
			R 418
			R 419
D 955	Diode	ERA15-02VH	
D 956	Diode	HZS6L(B2)	
D 957	Diode	HZS9L(B3)	R 420
D 958	Diode	HZS9L(A2)	R 421
L 401	Ferri-Inductor	LAU2R2K	R 422
			R 423
			R 424
L 402	Ferri-Inductor	LAU2R2K	
L 403	Inductor	LCTA100J3225	
L 404	Inductor	LCTA100J3225	R 425
L 601	Ferri-Inductor	LAU2R2K	R 426
L 602	Ferri-Inductor	LAU101K	R 427
			R 431
			R 435
L 603	Ferri-Inductor	LAU2R2K	
L 604	Ferri-Inductor	LAU2R2K	
L 605	Ferri-Inductor	LAU2R2K	R 436
L 701	Ferri-Inductor	LAU101K	R 439
L 751	Ferri-Inductor	LAU2R2K	R 440
			R 441
			R 448
L 801	Coil	CTH1227	
L 951	Coil 600 μ H	CTH1219	
TH 833	Thermistor	CCX1042	R 601
CF 601	Filter	CTF1071	R 602
X 401	Crystal Resonator 7.200MHz	CSS1379	R 603
			R 604
			R 605
X 601	Radiator 12.58291MHz	CSS1402	
X 701	Crystal Resonator 4.332MHz	CSS1056	
VR 701	Semi-fixed 22k Ω (B)	CCP1321	
	FM/AM Tuner Unit	CWE1466	
BZ 601	Buzzer	CPV1011	

====Circuit Symbol and No.====Part Name	Part No.	====Circuit Symbol and No.====Part Name	Part No.
R 606	RS1/10S473J	R 751	RS1/10S222J
R 607	RS1/10S472J	R 752	RS1/10S223J
R 608	RD1/4PU102J	R 753	RS1/10S472J
R 610	RS1/10S473J	R 754	RS1/10S102J
R 628	RS1/10S472J	R 755	RS1/10S102J
R 629	RS1/10S472J	R 756	RS1/10S473J
R 630	RS1/10S102J	R 757	RS1/10S473J
R 631	RD1/4PU153J	R 758	RS1/10S102J
R 632	RD1/4PU102J	R 759	RS1/10S101J
R 633	RS1/10S103J	R 760	RS1/10S620J
R 634	RS1/10S103J	R 761	RS1/10S101J
R 635	RS1/10S473J	R 801	RS1/10S103J
R 636	RS1/10S473J	R 802	RS1/10S562J
R 637	RS1/10S102J	R 803	RS1/10S123J
R 638	RS1/10S822J	R 804	RS1/10S912J
R 639	RS1/10S222J	R 805	RS1/8S472J
R 640	RS1/10S223J	R 806	RS1/10S473J
R 641	RS1/10S222J	R 807	RS1/10S224J
R 642	RS1/10S103J	R 808	RS1/10S224J
R 643	RS1/10S222J	R 810	RS1/10S204J
R 644	RS1/10S222J	R 822	RS1/8S225J
R 645	RS1/10S103J	R 823	RS1/8S225J
R 646	RA4C222J	R 825	RS1/8S474J
R 647	RA4C222J	R 826	RS1/8S474J
R 648	RA4C473J	R 827	RS1/8S105J
R 649	RS1/10S103J	R 829	RD1/2PM182J
R 650	RS1/10S392J	R 830	RD1/2PM182J
R 651	RS1/10S472J	R 831	RS1/10S152J
R 652	RS1/10S472J	R 832	RS1/10S103J
R 653	RS1/10S222J	R 834	RS1/10S103J
R 654	RS1/10S222J	R 836	RS1/8S391J
R 655	RS1/10S473J	R 837	RS1/8S391J
R 659	RS1/10S473J	R 951	RS1/10S473J
R 660	RS1/10S102J	R 952	RS1/10S102J
R 661	RS1/10S473J	R 953	RS1/10S102J
R 662	RS1/10S152J	R 954	RS1/10S101J
R 663	RS1/10S152J	R 955	RS1/10S103J
R 665	RS1/10S473J	R 956	RS1/10S473J
R 667	RS1/10S104J	R 957	RS1/10S102J
R 669	RS1/10S473J	R 958	RS1/10S473J
R 673	RS1/10S222J	R 959	RS1/10S102J
R 674	RS1/10S222J	R 961	RS1/10S1R0J
R 701	RS1/10S102J	R 962	RS1/10S103J
R 702	RS1/10S333J	R 963	RS1/10S223J
R 704	RS1/10S102J	R 964	RS1/10S472J
R 705	RS1/10S102J	R 965	RS1/10S473J
R 706	RA4C102J	R 966	RS1/10S272J
R 710	RS1/10S222J	R 967	RD1/4PU152J
R 711	RS1/10S222J	R 968	RS1/10S152J
R 712	RS1/10S681J	R 969	RD1/2PM390J
R 713	RS1/10S684J	R 970	RD1/2PM390J
R 714	RS1/10S562J		
R 715	RS1/10S562J	CAPACITORS	
R 716	RS1/10S104J	C 201	CKSQYB224K16
R 717	RS1/10S104J	C 202	CKSQYB224K16
R 718	RS1/10S103J	C 203	CKSQYB224K16
R 719	RS1/10S473J	C 204	CKSQYB224K16
R 720	RS1/10S102J	C 205	CKSQYB105K16
R 721	RS1/10S102J		
R 722	RS1/10S562J	C 206	CKSQYB105K16
R 723	RS1/10S105J	C 207	CKSQYB105K16
R 724	RS1/10S0R0J	C 208	CKSQYB105K16
R 725	RS1/10S224J	C 209	CKSQYB105K16
R 726	RS1/10S224J	C 210	CKSQYB105K16
R 727	RS1/10S222J	C 211	CKSQYB153K50
R 728	RS1/10S222J	C 212	CKSQYB153K50
R 729	RS1/10S223J	C 215	CEJA2R2M50
R 730	RS1/10S223J	C 216	CEJA2R2M50
R 731	RS1/10S103J	C 219	CCSQLS221J50
R 732	RS1/10S224J		

====Circuit Symbol and No.====Part Name	Part No.	====Circuit Symbol and No.====Part Name	Part No.
C 220	CCSQL221J50	C 712	CEJA4R7M35
C 223	CEJA470M10	C 713	CKSQYB223K50
C 224	CKSQYF104Z25	C 714	CCSQL101J50
C 225	CEJA100M16	C 716	CKSQYB103K50
C 233	CKSQYB332K50	C 717	CEJA2R2M50
C 234	CKSQYB332K50	C 718	CEJA2R2M50
C 301	CKSQYB224K16	C 719	CKSQYB471K50
C 302	CKSQYB224K16	C 720	CKSQYB223K50
C 303	CKSQYB224K16	C 751	CKSQYB104K25
C 304	CKSQYB224K16	C 752	CKSQYB102K50
C 305	CEJA100M16	C 801	CEJA100M16
C 306	CKSQYB105K16	C 803	CKSQYB222K50
C 308	CEJA330M10	C 805	CCH1327
C 309	CCH1178	C 806	CCG1089
C 310	CKSQYB104K25	C 814	CCSQL101J50
C 311	CKSQYB103K50	C 815	CCSQL101J50
C 401	CKSQYB223K50	C 816	CKSQYB103K50
C 402	CKSQYB223K50	C 817	CCG1091
C 403	CKSQYB223K50	C 818	CCH1327
C 404	CKSQYB273K50	C 820	CCG1095
C 406	CKSQYB223K50	C 951	470μF/16V
C 407	CKSQYB102K50	C 952	CCH1183
C 408	CEJA220M16	C 953	CEJA470M10
C 409	CKSQYB103K50	C 954	CEJA101M10
C 410	CEJA220M6R3	C 956	CKSQYB103K50
C 411	CEJA220M10	C 958	CEJA101M10
C 412	CKSQYB103K50	C 959	CCSQL101J50
C 413	CKSQYB103K50		
C 414	CCH1250		
C 415	CKSQYB103K50	 Unit Number : CWM6266	Unit Name : Keyboard Unit
C 416	CKLSR473K16	MISCELLANEOUS	
C 417	CCSQL101J50	IC 901	IC
C 418	CKSQYB103K50	IC 902	
C 420	CKSQYB103K50	Q 901	Transistor
C 421	CKSQYB103K50	Q 902	Transistor
C 422	CEJA220M6R3	Q 903	Transistor
C 423	CKSYB473K25		
C 424	CCH1250	Q 904	Transistor
C 425	CKSQYB103K50	Q 905	Transistor
C 426	CEJAR47M50	D 901	Diode
C 427	CKSQYB103K50	D 902	Diode
C 429	CCSQCH150J50	D 903	LED
C 430	CCSQCH150J50	D 904	LED
C 431	CKSQYB103K50	D 905	LED
C 432	CKSQYB223K50	L 901	Inductor
C 437	CCSQL101J50	X 901	Ceramic Resonator 4.97MHz
C 608	CKSQYF105Z25	S 901	Switch
C 610	CKSQYB225K10	S 902	Switch
C 611	CKSQYB104K25	S 903	Switch
C 612	CCSQCH200J50	S 904	Switch
C 613	CCSQCH200J50	S 905	Switch
C 614	CKSQYB103K50	S 906	Switch
C 615	CSZS4R7M16	S 907	Switch
C 616	CCSQL101J50	S 908	Switch
C 617	CKSQYB103K50	S 909	Switch
C 619	CKSQYB102K50	S 910	Switch
C 620	CEJA100M16	S 911	Switch
C 621	CCSQL101J50	S 912	Switch
C 622	CEJA220M10	S 913	Switch
C 701	CKSQYF104Z25	S 914	Switch
C 702	CKSQYB222K50	S 915	Switch
C 703	CKSQYB104K25	S 916	Switch
C 704	CKSQYB105K10	S 917	Switch
C 705	CKSQYB104K25	S 918	Switch
C 706	CKSQYB472K50	S 919	Switch
C 707	CEJA4R7M35	S 920	Switch
C 708	CKSQYB104K25	S 921	Switch
C 709	CCSQCH220J50		
C 710	CCSQCH220J50		
C 711	CKSQYB104K25		

KEH-P7800R,P6800R

====Circuit Symbol and No.====Part Name	Part No.
S 922 Switch	CSG1115
S 923 Switch	CSG1113
LCD 901 LCD	CAW1501
EL 901 EL	CEL1587

RESISTORS

R 901	RS1/10S222J
R 902	RS1/10S222J
R 903	RS1/10S472J
R 904	RS1/10S121J
R 905	RS1/10S2R2J
R 906	RS1/10S470J
R 907	RS1/10S470J
R 908	RS1/10S472J
R 909	RS1/8S561J
R 910	RS1/8S561J
R 911	RS1/8S561J
R 912	RS1/8S561J
R 913	RS1/8S561J
R 914	RS1/8S561J
R 915	RS1/8S751J
R 916	RS1/8S751J
R 917	RS1/8S561J
R 918	RS1/8S561J
R 919	RS1/8S561J
R 920	RS1/8S561J
R 921	RS1/8S561J
R 922	RS1/8S561J
R 923	RS1/8S621J
R 924	RS1/10S473J
R 925	RS1/10S272J
R 926	RS1/10S473J
R 927	RS1/10S272J
R 930	RS1/8S102J
R 931	RS1/8S102J
R 932	RS1/8S102J
R 933	RS1/8S102J

CAPACITORS

C 901	CSZSR100M6R3
C 902	CKSQYF104Z50
C 903	CSZSR100M6R3
C 904	CKSQYB103K25
C 905	CKSQYB103K25
C 906	CKSQYB103K25
C 907	CKSQYF104Z50

D Unit Number : EWM1018(KEH-P7800R)
Unit Name : Deck Unit

MISCELLANEOUS

IC 251	IC	CXA2560Q
IC 351	IC	PA2020A
D 352	Diode	1SS355
VR 301	Semi-fixed 33kΩ(B)	CCP1280
VR 302	Semi-fixed 33kΩ(B)	CCP1280

RESISTORS

R 255	RS1/16S221J
R 256	RS1/16S221J
R 257	RS1/16S102J
R 258	RS1/16S102J
R 271	RS1/16S102J
R 272	RS1/16S102J
R 273	RS1/16S102J
R 274	RS1/16S102J
R 281	RS1/8S0R0J
R 282	RS1/8S0R0J

====Circuit Symbol and No.====Part Name	Part No.
R 283	RS1/8S0R0J
R 284	RS1/8S0R0J
R 285	RS1/16S0R0J
R 286	RS1/16S0R0J
R 287	RS1/8S0R0J

R 290	RS1/8S0R0J
R 301	RS1/16S183J
R 322	RS1/16S102J
R 323	RS1/8S0R0J
R 351	RS1/16S102J

R 352	RS1/16S102J
R 353	RS1/16S102J
R 354	RS1/16S102J
R 355	RS1/10S274J
R 362	RS1/8S181J

R 373	RS1/8S0R0J
R 374	RS1/8S0R0J
R 375	RS1/8S0R0J
R 401	RS1/16S472J
R 402	RS1/16S163J

R 403	RS1/16S823J
-------	-------------

CAPACITORS

C 251	CKSRYB331K50
C 252	CKSRYB331K50
C 253	CKSRYB331K50
C 254	CKSRYB331K50
C 255	CKSRYB103K25

C 256	CKSRYB103K25
C 272	CKSQYB104K16
C 273	CEJA220M16
C 301	CKSYB104K50
C 302	CKSYB104K50

C 309	CKSQYB104K16
C 310	CKSQYB104K16
C 313	CCSQCH101K50
C 351	CKSYB224K25
C 352	CKSQYB392K50

C 353	CKSQYB103K50
C 354	CKSQYB103K50
C 355	CKSYB104K50
C 356	CKSQYB103K50
C 401	CKSQYB334K16

C 402	CKSQYB472K50
C 403	CKSQYB683K16

D Unit Number : EWM1021(KEH-P6800R)
Unit Name : Deck Unit

MISCELLANEOUS

IC 251	IC	CXA2559Q
IC 351	IC	PA2020A
D 352	Diode	1SS355

RESISTORS

R 255	RS1/16S221J
R 256	RS1/16S221J
R 257	RS1/16S102J
R 258	RS1/16S102J
R 271	RS1/16S102J

R 272	RS1/16S102J
R 273	RS1/16S102J
R 274	RS1/16S102J
R 281	RS1/8S0R0J
R 282	RS1/8S0R0J

====Circuit Symbol and No.====	Part Name	Part No.
R 283		RS1/8S0R0J
R 284		RS1/8S0R0J
R 285		RS1/16S0R0J
R 286		RS1/16S0R0J
R 287		RS1/8S0R0J
R 290		RS1/8S0R0J
R 301		RS1/16S183J
R 302		RS1/16S163J
R 303		RS1/16S163J
R 304		RS1/16S163J
R 305		RS1/16S163J
R 323		RS1/8S0R0J
R 351		RS1/16S102J
R 352		RS1/16S102J
R 353		RS1/16S102J
R 354		RS1/16S102J
R 355		RS1/10S274J
R 362		RS1/8S181J
R 373		RS1/8S0R0J
R 374		RS1/8S0R0J
R 401		RS1/16S472J
R 402		RS1/16S163J
R 403		RS1/16S823J

CAPACITORS

C 251		CKSRYB331K50
C 252		CKSRYB331K50
C 253		CKSRYB331K50
C 254		CKSRYB331K50
C 255		CKSRYB103K25
C 256		CKSRYB103K25
C 272		CKSQYB104K16
C 273		CEJA220M16
C 301		CKSYB104K50
C 302		CKSYB104K50
C 313		CCSQCH101K50
C 351		CKSYB224K25
C 352		CKSQYB392K50
C 353		CKSQYB103K50
C 354		CKSQYB103K50
C 355		CKSYB104K50
C 356		CKSQYB103K50
C 401		CKSQYB334K16
C 402		CKSQYB472K50
C 403		CKSQYB683K16

E Unit Number :
Unit Name : PCB Unit(KEH-P7800R)

S 1	Switch (Load)	ESG1004
S 2	Switch (70 μ S)	ESG1004
EGN 1	Photo-Interrupter	EGN1005

E Unit Number :
Unit Name : PCB Unit(KEH-P6800R)

S 1	Switch (Load)	ESG1004
EGN 1	Photo-Interrupter	EGN1005

F Unit Number :
Unit Name : Reel PCB

EGN 2	Photo-Interrupter	EGN1006
EGN 3	Photo-Interrupter	EGN1006

Miscellaneous Parts List

M 1	Motor Unit (Main)	EXA1490
M 2	Motor Unit (Sub)	EXA1485
HD 1	Head Assy	EXA1506
	Fuse(10A)	CEK1136

6. ADJUSTMENT

● Connection Diagram

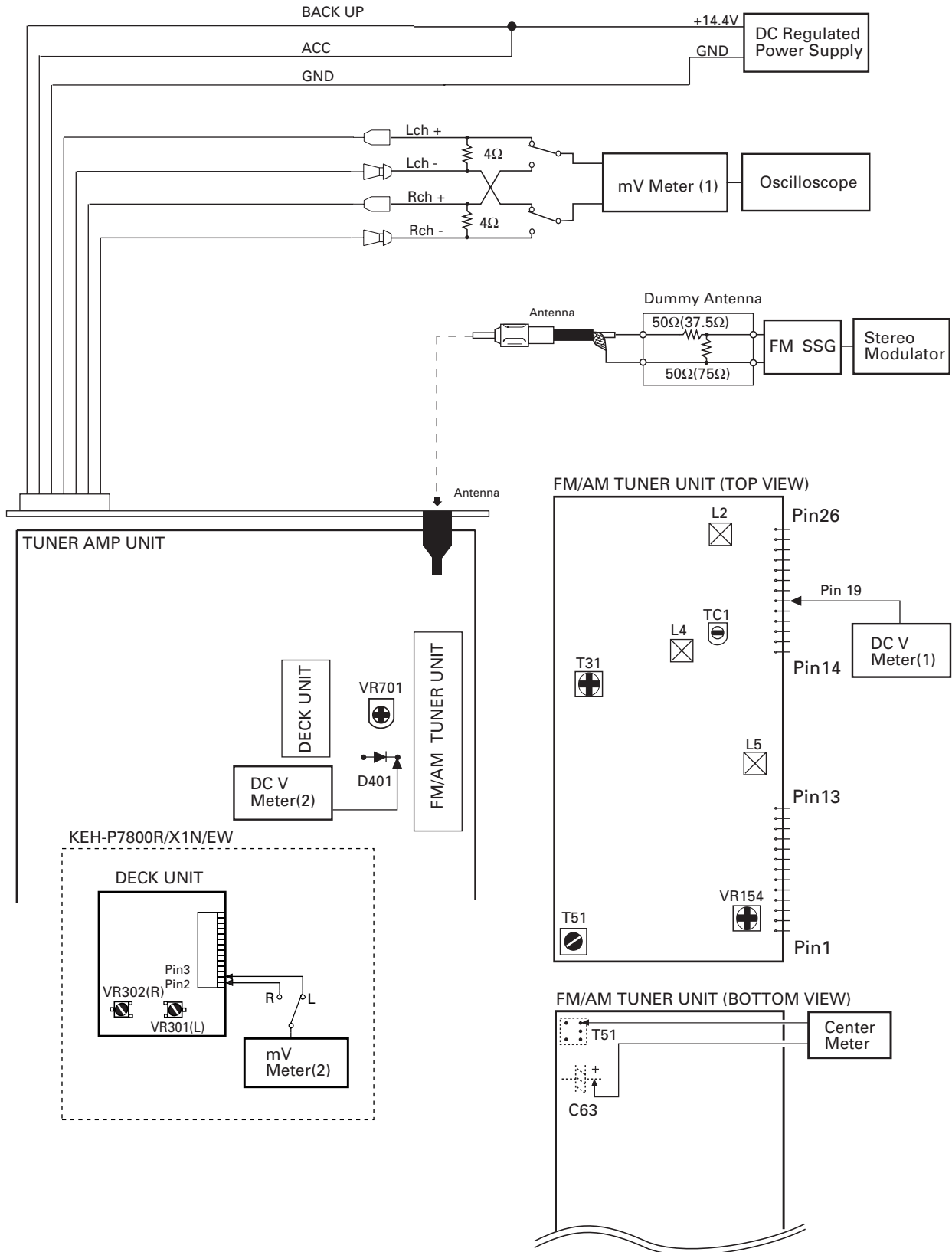

FM ADJUSTMENT

Modulation M:MONO MOD., 400Hz 30%(22.5kHz Dev.) or 400Hz 100%(75kHz Dev.)

S:STEREO MOD., 1kHz, L or R=30%(20.25kHz+7.5kHz Dev.)

S2:STEREO MOD., 400Hz, L or R=60%(40.50kHz+7.5kHz Dev.)

NOTE:Before proceeding to further adjustments after switching power ON, let the tuner run for ten minutes to allow the circuits to stabilize.

	No.	FM SSG		Displayed	Adjustment Point	Adjustment Method (Switch Position)
		Frequency(MHz)	Level(dBf)	Frequency(MHz)		
TUN Volt	1	108.0	L5	DC V Meter(1) : 6V
IF	2	98.1 M	60	98.1	T51	Center Meter : 0
ANT Coil	3	98.1 M	5	98.1	L2	mV Meter(1) : Maximum
RF Coil	4	98.1 M	5	98.1	L4	mV Meter(1) : Maximum
RF Trimmer	5	129.3 M	60—80	107.9	TC1	mV Meter(1) : Minimum
	6	RF Coil and RF Trimmer shall be adjusted twice or more				
IFT	7	98.1 M	5	98.1	T31	mV Meter(1) : Maximum (STEREO MODE)
ARC	8	98.1 S	40	98.1	VR154	mV Meter(1) : Separation 5dB (STEREO MODE)

RDS SL ADJUSTMENT

	No.	FM SSG		Displayed	Adjustment Point	Adjustment Method (Switch Position)
		Frequency(MHz)	Level(dBf)	Frequency(MHz)		
	1	104.0 S2	35	104.0	VR701	DC V Meter(2) : 1.75V+0.05V,-0.35V

DOLBY B NR ADJUSTMENT

No.	Test Tape	Adjustment Point	Adjustment Method (Switch Position)
1	NCT-150 (400Hz,200nwb/m)	VR301(Lch),VR302(Rch)	mV Meter(2) : -6dBs±1.0dB (DOLBY NR Switch : OFF)

7. GENERAL INFORMATION

7.1 PARTS

7.1.1 IC

PML003AM

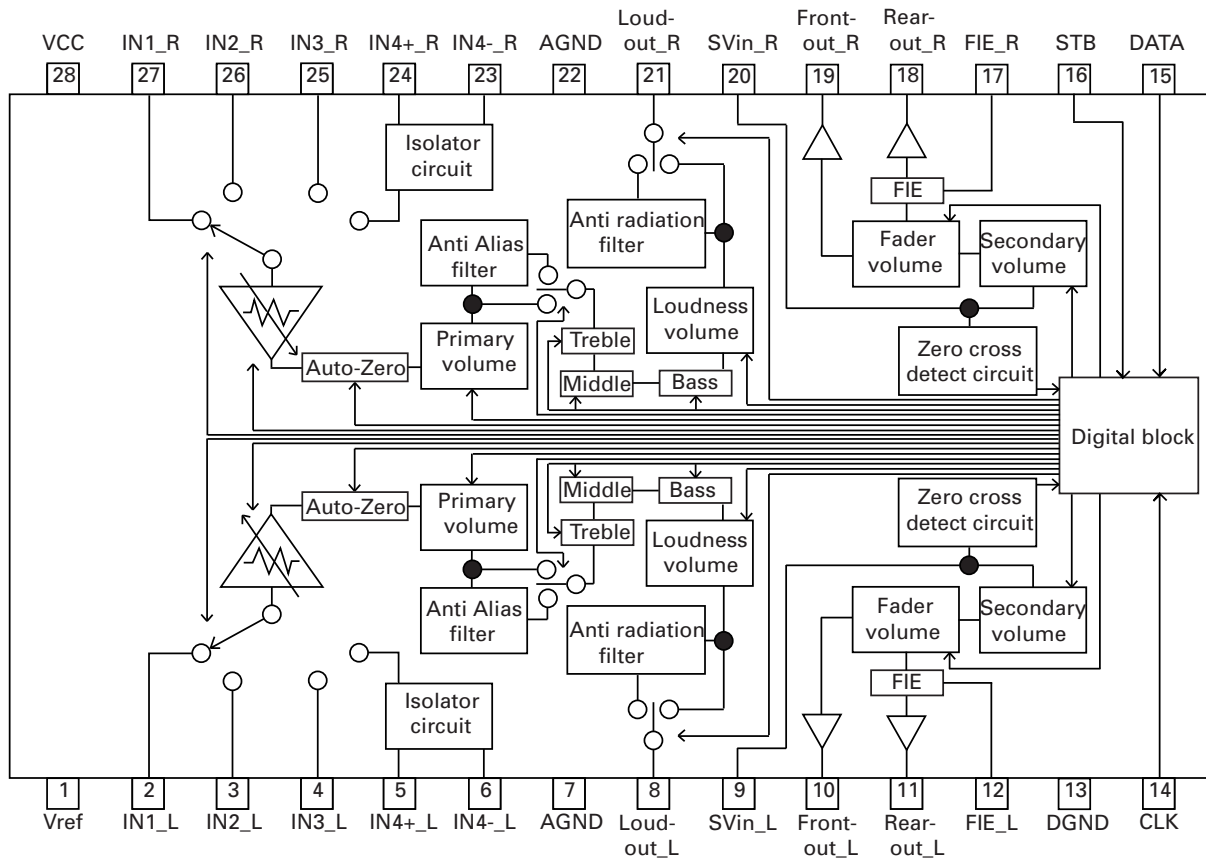

PAL005A

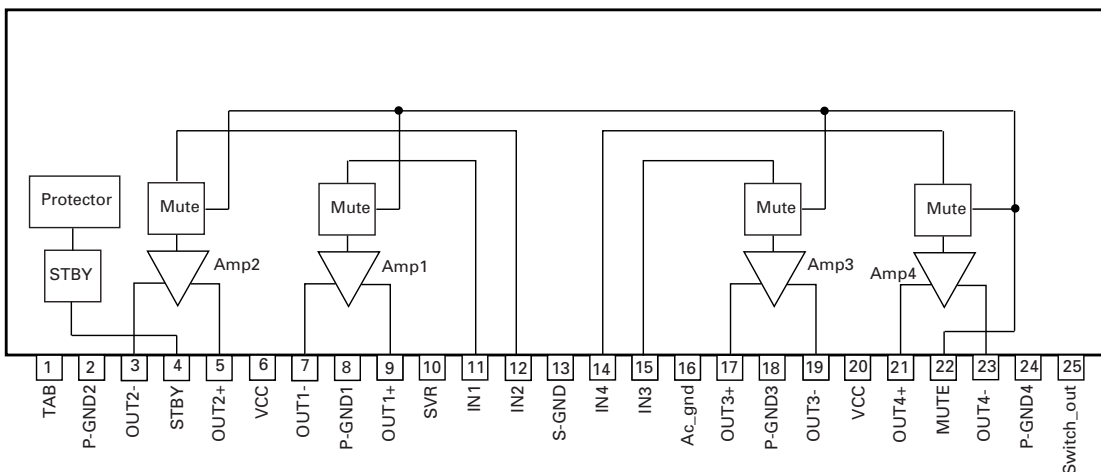

PML005A

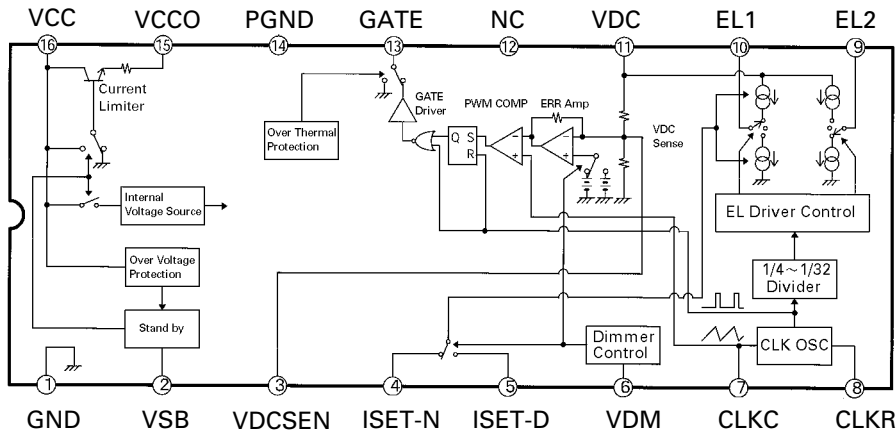

CXA2560Q

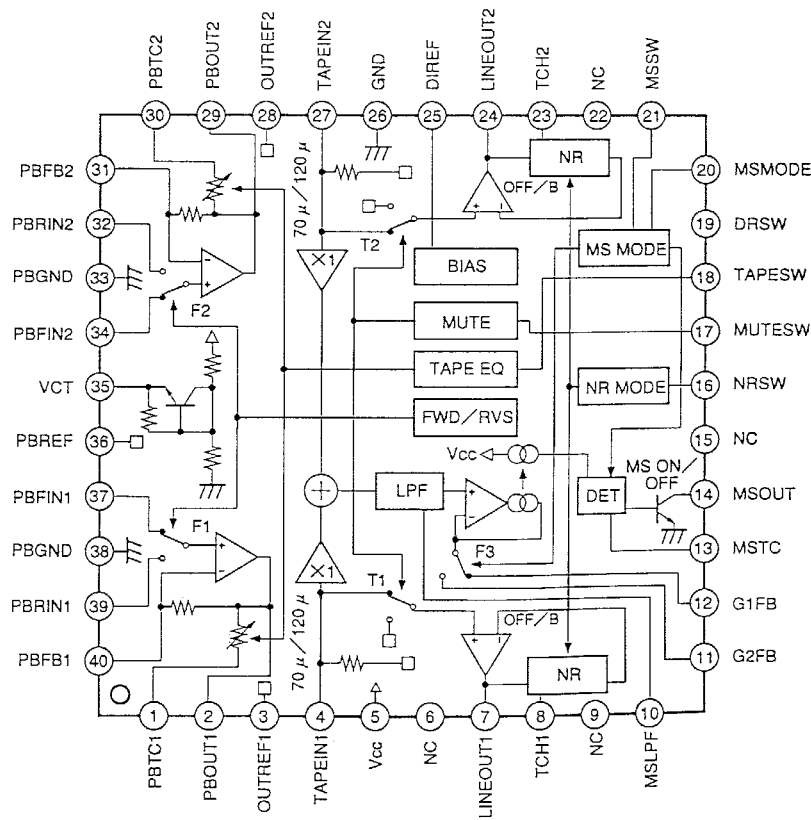

● Pin Functions (PD4975B)

Pin No.	Pin Name	I/O	Function and Operation
1	SWVDD	O	Key board unit power supply control output
2	DSENS	I	Grille detach sense
3	CSENS	I	Flap close sense input
4	ISENS	I	Illumination sense input
5	TESTIN	I	Test mode input/test enable
6	DRST	O	Decoder reset output
7	NC		Not used
8	SK	I	SK signal input
9	RECIVE	O	During RDS data reception output
10	NC		Not used
11	RESET	I	Reset input
12	XT2		Not used
13	XT1		Connect to GND
14	VSS		GND
15	X2		Crystal oscillator connection pin
16	X1		Crystal oscillator connection pin
17	REGCOFF		VSS
18	REGC		VSS
19	VDD		Power supply
20	ILMPW	O	Illumination power supply control output
21	SYSPW	O	System power supply control output
22	ADPW	O	A/D converter power
23	LCDPW	O	LCD back light power supply control output
24	IPPW	O	Power supply control output for IP BUS interface IC
25	ASENBO	O	Slave power supply control output
26	PRSBSW	I	Not used
27	TELIN	I	TEL mute signal input
28	MUTE	O	Mute output
29	DIM	O	Dimmer select output
30	NC		Not used
31	FM	O	FM power control output
32	AM	O	AM power control output
33	VCK	O	Clock output for electronic volume
34	VST	O	Strobe pulse output for electronic volume
35	VDT	O	Data output for electronic volume
36	TMUTE	O	Tuner mute output
37	NC		Not used
38	SD	I	SD input
39	ST	I	FM stereo input
40	VSS		GND
41	VDD		Power supply
42	MDSENS	I	Modulation detect input
43	NC		Not used
44	RDSLK	I	RDS LK signal input
45	CURRO	O	Tuner voltage FIX output
46	RDT	I	RDS demodulation data input
47	DRELAY	O	External relay output
48	DRSENS	I	Door open/close sense input
49	DRSYS	O	Door system select output
50	DLED	O	Alarm LED output
51	DLSENS	I	Door lock sense input
52	STCUT	O	Starter cut off output
53	MOSENS	I	Motion/window damage sensor input
54	MSIN	I	MS sense
55	MTLSW	I	Metal sense input
56	POS	I	Position sense
57	RES	I	Cassette mechanism reverse end sense input
58	NES	I	Cassette mechanism forward end sense input
59	DIRO	O	Head F/R select output
60	PLAY	O	MS gain select output

Pin No.	Pin Name	I/O	Function and Operation
61	RIMUTE	O	Mute output when RI
62	PCL	O	Clock adjustment output
63	NR	O	NR output
64	SC2	O	Cassette mechanism sub motor control output
65	SC1	O	Cassette mechanism sub motor control output
66	CM	O	Cassette mechanism capstan motor control output
67	\overline{STBY}	O	Drive IC control output
68	\overline{LOADSW}	I	Cassette mechanism loading detect input
69-71	NC		Not used
72	DALMON	O	"L" output when ACC OFF
73	TEST	I	Connect to GND
74	SL	I	Signal level input
75	SEL	I	Select input for the destination
76	NC		Not used
77	CL	I	Synchronizing signal input
78	NL	I	Noise level input
79-81	NC		Not used
82	AVDD		Positive power supply terminal for analog circuit
83	AVREF1		A/D converter reference voltage
84	AVSS		A/D GND
85	RX	I	IP BUS data input
86	TX	O	IP BUS data output
87	GND		GND
88	\overline{LDET}	I	PLL lock sense input
89	RCK	I	RDS demodulation clock input
90	RDS57K	I	57kHz pulse count sense input
91	NC		Not used
92	ASENS	I	ACC power sense input
93	BSSENS	I	Back up power sense input
94	TUNPDI	I	PLL IC data input
95	KEYDT	I	Display data input
96	DPDT	O	Display data output
97	TUNPCK	O	PLL IC clock
98	TUNPDO	O	PLL IC data output
99	TUNPCE	O	PLL IC chip enable
100	PEE	O	Beep tone output

*PD4975B

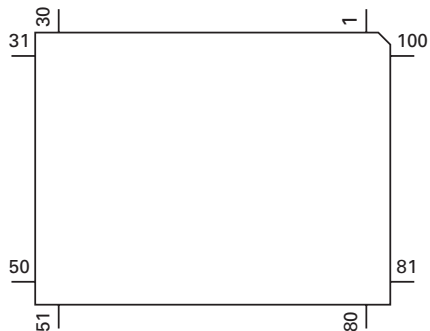

IC's marked by* are MOS type.

Be careful in handling them because they are very liable to be damaged by electrostatic induction.

● Pin Functions(PD6294A)

Pin No.	Pin Name	I/O	Function and Operation
1	VSS		GND
2	X1		Crystal oscillator connection pin
3	X0		Crystal oscillator connection pin
4	RST	I	System reset
5,6	MODE1,0		GND
7	GRN/AMB	O	Green/Amber select output
8	SO	O	UART output
9	SI	I	UART input
10	REMIN	I	Remote control reception
11	RVER		Not used
12	NC		Not used
13-16	KDT4-1	I	Key data input
17-22	KST6-1	O	Key strobe output
23	VCC		5V
24-73	SEG49-0	O	LCD segment output
74-77	COM3-0	O	Common driver output
78-80	V3-1		LCD bias power supply

CXA2559Q

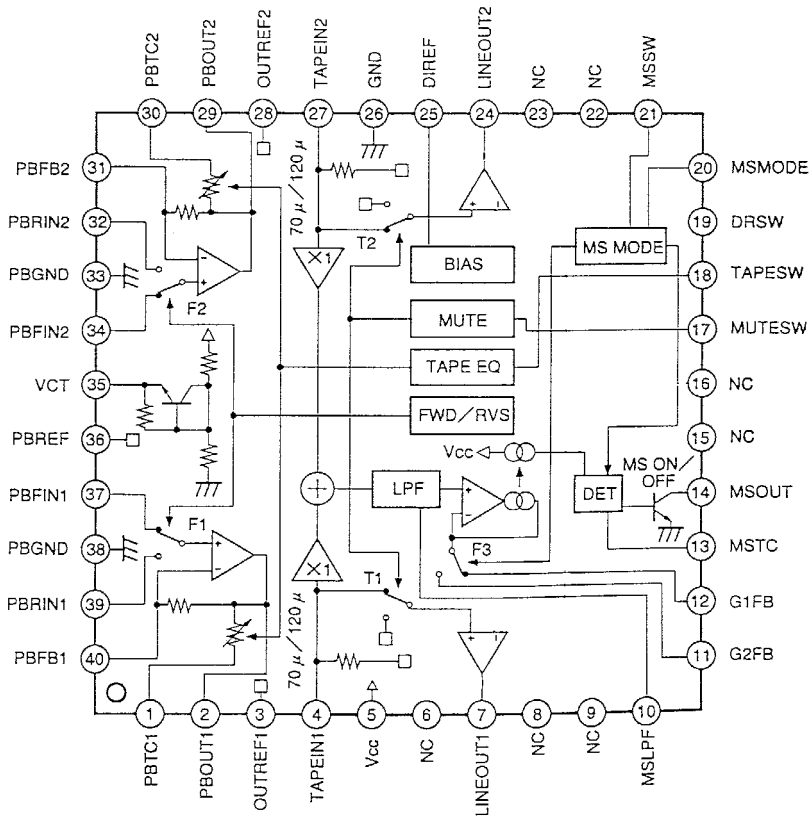

*PD6294A

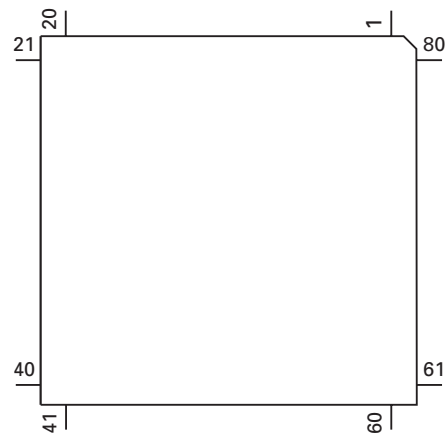

7.1.2 DISPLAY

● CAW1501

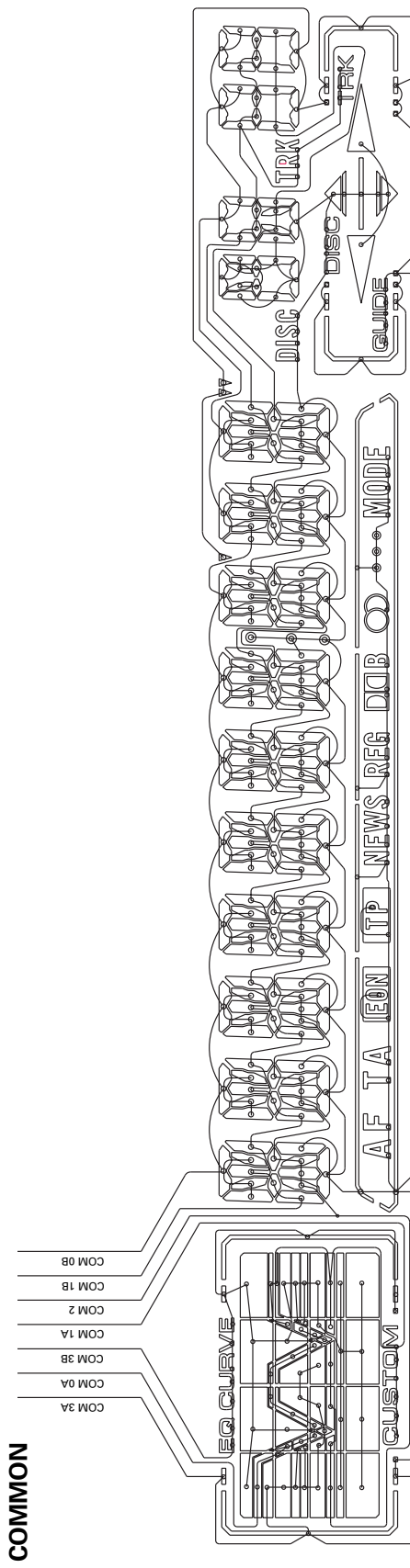
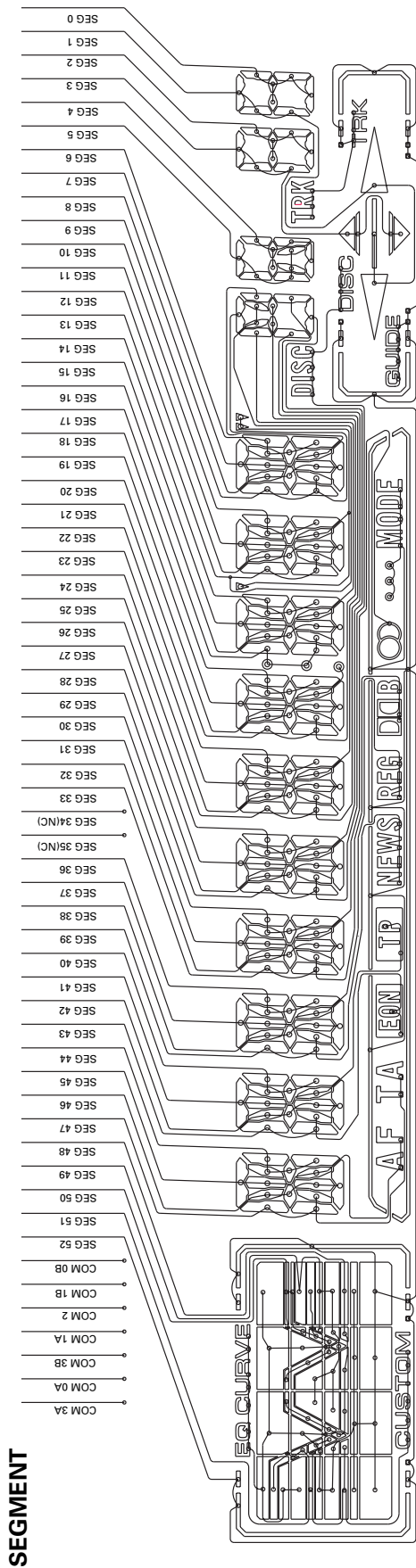

7.2 DIAGNOSIS

7.2.1 DISASSEMBLY



● Removing the Case(not shown)

- 1.Remove the two screws.
- 2.Remove the Case.

● Removing the Cassette Mechanism Module (not shown)

- 1.Remove the four screws.
- 2.Disconnect the connector, and then removing the Cassette Mechanism Module.

● Removing the Panel Assy(Fig.1)

-  Remove the two screws.
-  Disconnect the two connectors.
-  Disengage the stopper at two locations indicated and remove the Panel Assy.

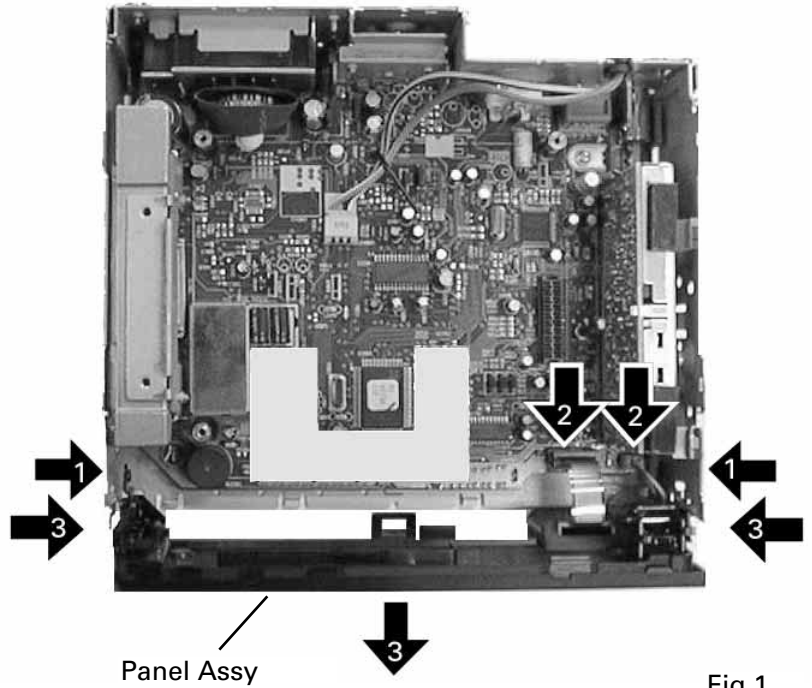





Fig.1

● Removing the Tuner Amp Unit(Fig.2)

-  Removing the two screws.
-  Removing the three screws.
-  Removing the screw.
-  Unbend the tabs at two locations indicated by arrow until straight. Remove the Tuner Amp Unit.

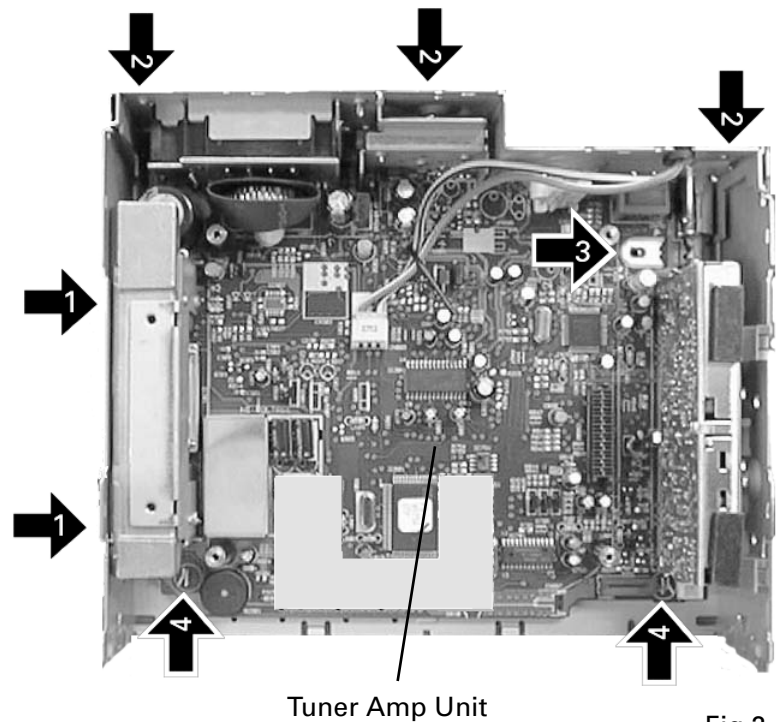
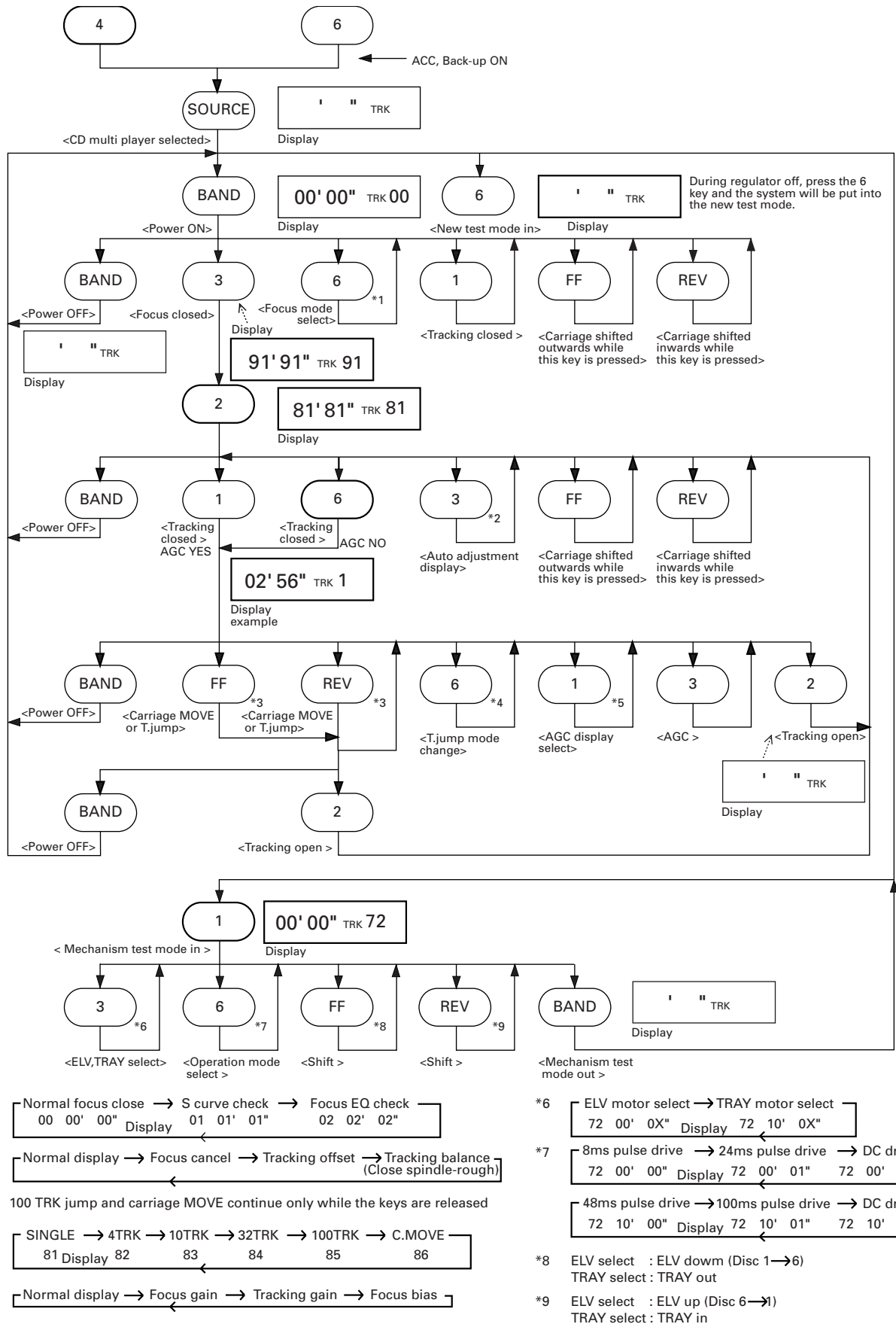

Fig.2

7.2.2 TEST MODE

● Flow Chart



● **New Test Mode(aging operation and setup analysis)**

The single CD player plays in normal mode. After being set up, it will display FOK (focus), LOCK (spindle), subcode, sound skip, protection against a mechanical error or the like, occurrence of an error, cause and time of an expiry, if any, (and disc number)

During the setup, the CD software operation status (internal RAM and C-point)is displayed.

(1) How to enter NEW TEST Mode

See the test mode flow chart Page 55.

(2) Relations of keys between TEST and NEW TEST Modes

Keys	Test Mode		New Test Mode	
	Regulator OFF	Regulator ON	PLAY in progress	Error Occurred, Protection Activated
BAND	Regulator ON	Regulator OFF	—	Time of occurrence/ cause of error select
FF	—	FWD-Kick	FF/TRACK+	—
REV	—	REV-Kick	REV/TRACK-	—
1	—	Tracking close	SCAN	—
2	—	Tracking open	MODE	—
3	—	Focus close	—	—
6	To New Test Mode	Jump Mode Select	AUTO/MANU	TRACK No./ time of occurrence select

Operations,such as EJECT, CD ON/OFF, etc. are performed normally

(3) Error Cause (Error Number) Code

Error Code	Classification	Mode	Description	Cause/Detail	Scratch, Stain, Vibration, Servo defect, etc...
40	ELECTRIC	PLAY	FOK=L 100ms	Put out of focus	
41	ELECTRIC	PLAY	LOCK=L 100ms	Spindle unlock	
42	ELECTRIC	PLAY	Subcode unacceptable 500ms	Failed to read subcode	
43	ELECTRIC	PLAY	Sound skipped	Last address memory operated	

(4) Indicating an Operation Status During Setup

Status No.	Description	Protection operation
01	Carriage home mode started	None
02	Carriage moving inwards	10-second time out, Home switch failed
03	Carriage moving outwards	10-second time out, Home switch failed
05	Carriage moving outwards	None
11	Setup started	None
12	Spindle turn/Focus search started	None
13	Waiting for focus closure (XSI=L)	Failure to close focus
10,14	Waiting for focus closure (FOK=H)	Failure to close focus
15, 16, 17	Focus closed, Tracking open	Focus disrupted
18	During focus AGC	Focus disrupted
19	During tracking AGC	Disrupted focus
20	Waiting for MIRR, LOCK or subcode read Carriage closed, SPINDLE=ADAPTIVE	Focus disrupted, MIRR NG, Failure to lock, failed to read subcode

(5) Example of Display.

- SET UP in progress
8 digits display LCD

TNo.	Min	Sec
11	11	11

- Operation (PLAY, SEARCH, etc.) in progress perfectly identical with that in the normal mode.

- Protection/Error upon occurrence(8 digits display LCD)

(a) Error number indicated

ERROR-xx

Select the display with the BAND key.

(b) Track number and absolute time indicated

TNo.	Min	Sec
10	40	05

● Error Number Indication

If the CD should fail to operate or if an error has taken place during operation the player will enter into the error mode, and the cause of the error will be numerically indicated.

This is aimed at assisting in analysis or repair.

(1) Basic Means of Display

- Examples of Display ERROR-xx

(2) Error Codes

Error Code	Classification	Description	Cause/Detail
10	ELECTRIC	Carriage home failure	Carriage doesn't move to or from the innermost position →Home switch failed and/or carriage immobile
11	ELECTRIC	Focus failure	Focus failed →Defects, disc upside-down, severe vibration
12	ELECTRIC	SETUP failure Subcode failure	Spindle failed to lock or subcode unreadable →Spindle defective, defect, severe vibration
14	ELECTRIC	Mirror failure	Unrecorded CD-R The disc is upside-down, defects, vibration
17	ELECTRIC	Set up failure	AGC protect failed →Defects, disc upside-down, severe vibration
19	ELECTRIC	Set up failure	Tracking error waveform is too unbalanced (>50%) or level is too small →The pickup unit or tracking error circuitry is N.G.
30	ELECTRIC	Search time out	Failed to reach target address →Carriage/tracking defective and/or defects
A0	SYSTEM	Power failure	Power overvoltage or short circuit detected →Switching transistor defective and/or power abnormal
A1	SYSTEM	Mechanism power failure	Mechanism elevation reference voltage is out of prescription →EREF adjustment VR and/or power abnormal
50	MECHANISM	An error upon ejection	MAG switch release time has time out Elevation time out when eject
60	MECHANISM	An error while putting in and out the tray	Tray in / out time has time out Tray is caught when put in
70	MECHANISM	An error upon elevation	Elevation time has time out
80	MECHANISM	An error with an empty magazine inserted	No disc is available

* Setup means a series of operations after focusing up to sound output.

7.3 BLOCK DIAGRAM

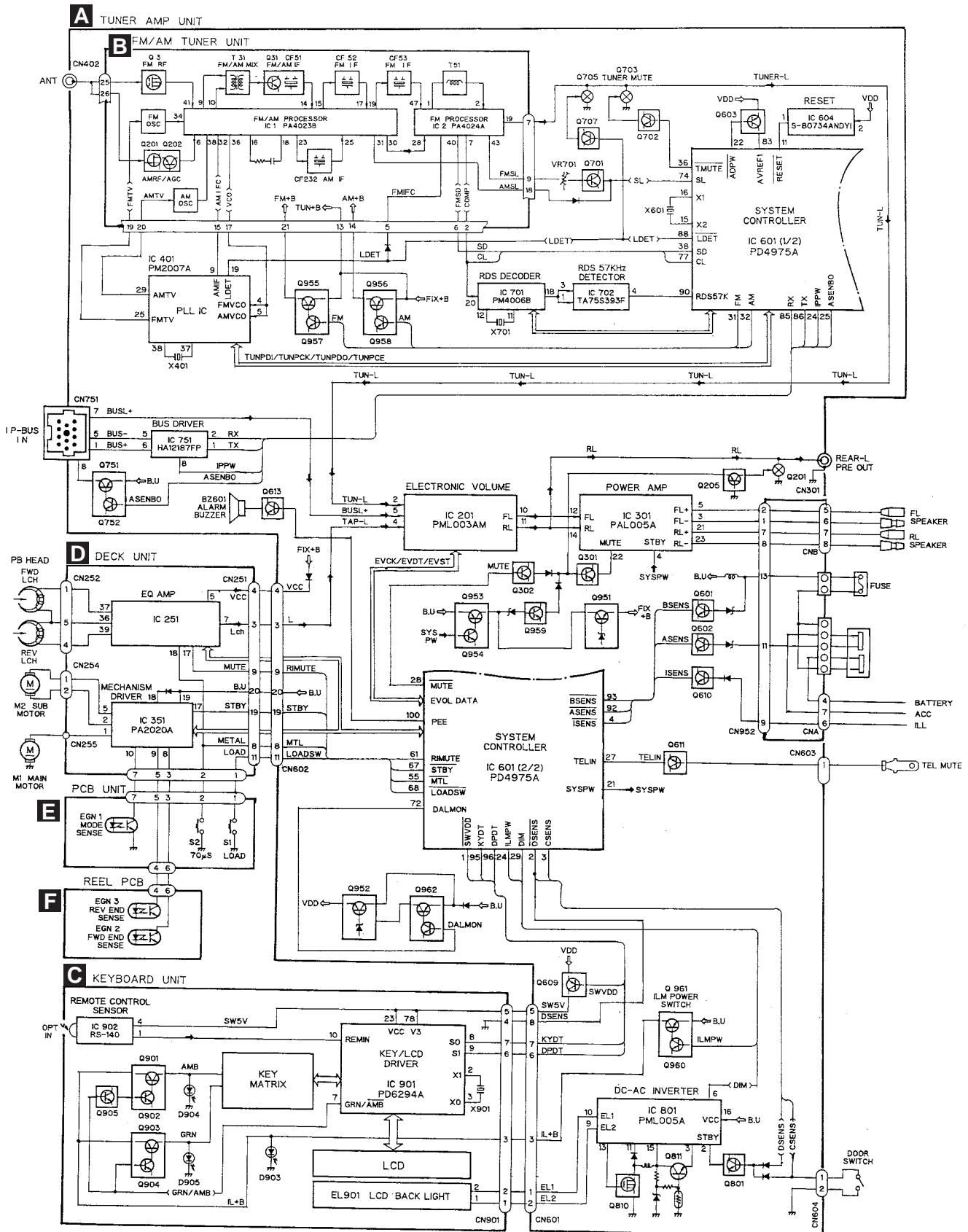

8. OPERATIONS AND SPECIFICATIONS

8.1 OPERATIONS

Head Unit

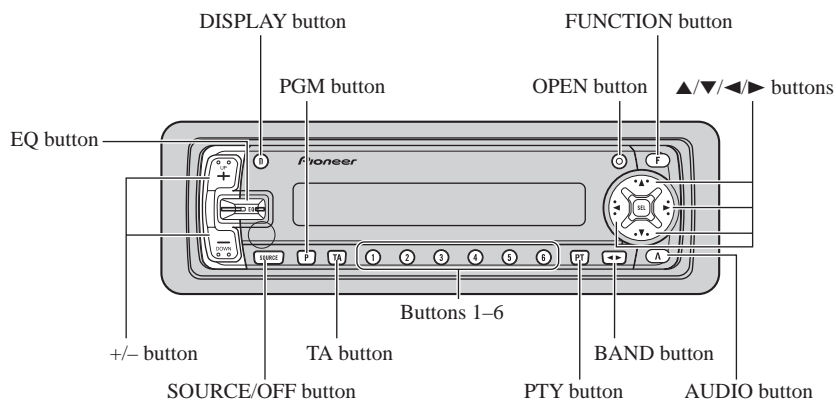

Steering Remote Controller

A steering remote controller that enables remote operation of the head unit is supplied. Operation is the same as when using buttons on the head unit.

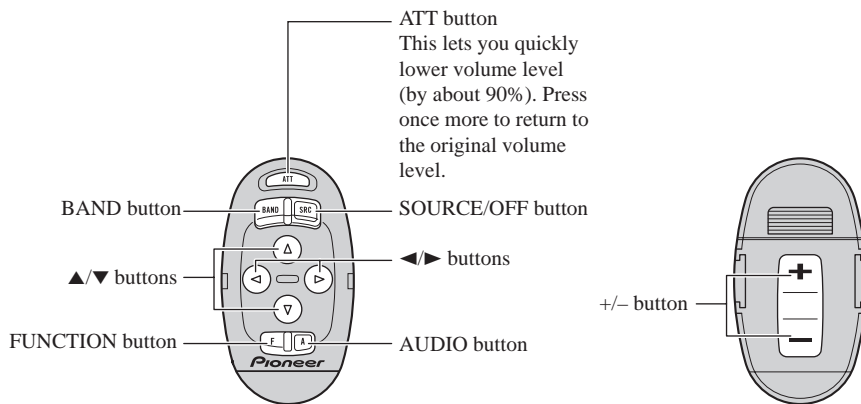

To Listen to Music

The following explains the initial operations required before you can listen to music.

Note:

- Loading a cassette in this product.

1. Select the desired source (e.g. tuner).

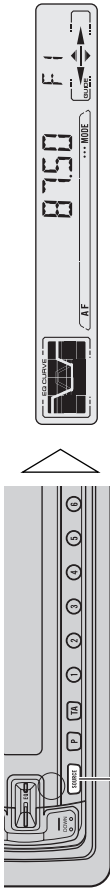

Each press changes the Source ...

Each press of the SOURCE/OFF button selects the desired source in the following order:
Tuner → Tape → Multi-MD player → Multi-CD player → AUX

Note:

- In the following cases, the sound source will not change:
 - * When a product is not connected to this product.
 - * When no tape is set in this product.
 - * When no magazine is set in the Multi-CD player.
 - * When the AUX (external input) is set to OFF.

2. Raise or lower the volume.

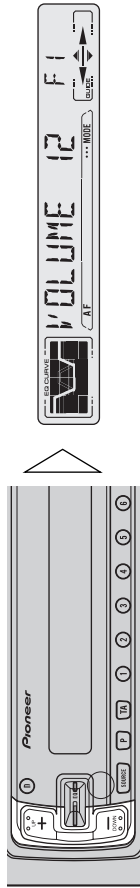

3. Turn the source OFF.

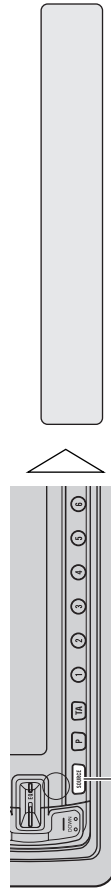

Hold for 1 second or more

Basic Operation of Tuner

This product's AF function can be switched ON and OFF. AF should be switched OFF for normal tuning operations.

Manual and Seek Tuning

- You can select the tuning method by changing the length of time you press the ◀▶ button.

Manual Tuning (step by step)	0.5 seconds or less
Seek Tuning	0.5 seconds or more

Note:

- If you continue pressing the button for longer than 0.5 seconds, you can skip broadcasting stations. Seek Tuning starts as soon as you stop pressing the button.

Note:

- "O" stereo indicator lights when a stereo station is selected.

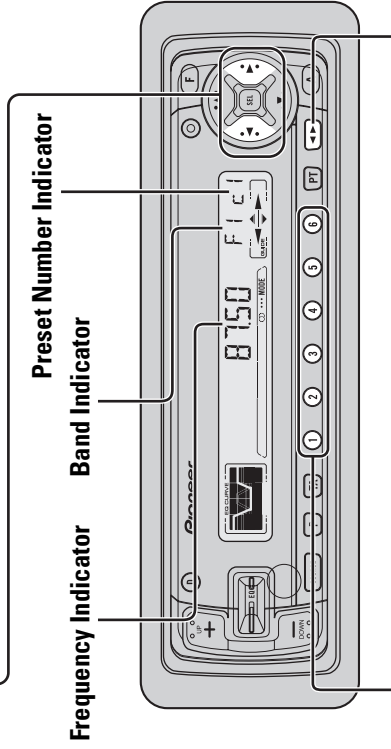

Preset Tuning

- You can memorize broadcast stations in buttons 1 through 6 for easy, one-touch station recall.

Preset station recall 2 seconds or less

Broadcast station preset memory 2 seconds or more

Band

F1 (FM1) → F2 (FM2)
→ F3 (FM3) → MW/LW

Note:

- Up to 18 FM stations (6 in F1 (FM1), F2 (FM2) and F3 (FM3)) and 6 MW/LW stations can be stored in memory.
- You can also use the ▲ or ▼ buttons to recall broadcast stations memorized in buttons 1 through 6.

Basic Operation of Cassette Player

Note:

- Be sure to close the front panel after loading or ejecting a cassette.

Fast Forward/Rewind and Music Search

- Each press of the **▶** button selects **Fast forward or Forward-Music Search**.
FF (Fast forward) → F-MS (Forward-Music Search) → Normal Playback
- Each press of the **◀** button selects **Rewind or Rewind-Music Search**.
REW (Rewind) → R-MS (Rewind-Music Search) → Normal Playback

Note:

- Fast forward/Rewind and Music Search can be canceled by pressing the **BAND** button.

Note:

- "METAL" appears on the display for 4 seconds when a metal or chrome tape is inserted. Nothing is displayed for a normal tape.

Open

Note:

- Use to open the front panel when loading or ejecting a cassette. (The illustration on the right shows the front panel open.)

Direction Indicator

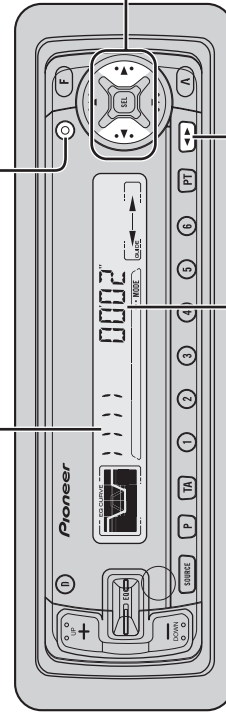

Cassette Loading Slot

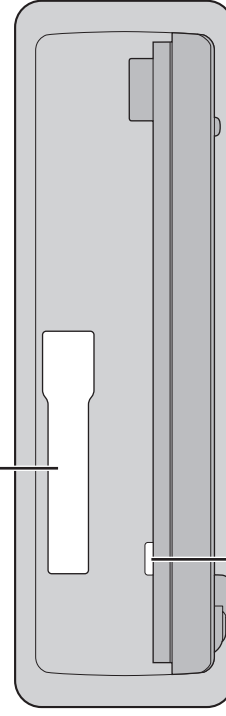

Elapsed Play Time Indicator

Note:

- The continuous playback time count starts at 00'00" at the following times.
 - * When a tape is inserted.
 - * When the tape direction is changed.
 - * When you rewind the tape side currently playing back to the beginning.
- The continuous playback time count is halted when fast-forwarding/rewinding and while the Music Search function is operating.

Direction Change

Note:

- The Tape function can be turned ON/OFF with the cassette tape remaining in this product.

Eject

Basic Operation of Multi-CD Player

This product can control one or more multi-CD players. (There are some types of Multi-CD players such as "CDX-F630S" which you cannot connect more than one.)

Switching the Multi-CD Player

Using a multiple connection adapter lets you connect up to three Multi-CD players.

M-CD 1 → M-CD 2 → M-CD 3
(Displayed for about 2 seconds.)

Track Search and Fast Forward/Reverse

- You can select between Track Search or Fast forward/Reverse by pressing the ◀/▶ button for a different length of time.

Track Search	0.5 seconds or less
Fast forward/Reverse	Continue pressing

Elapsed Play Time Indicator

Track Number Indicator

Disc Number Indicator

Disc Search

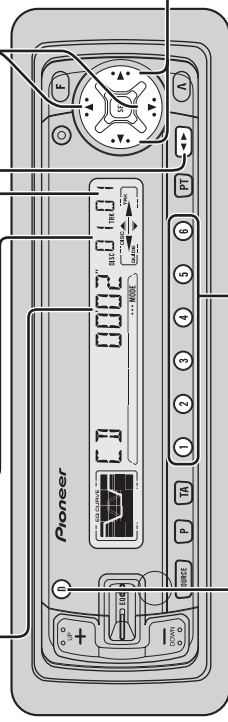

When playing a CD TEXT disc on a CD TEXT compatible Multi-CD Player such as the CDX-P650:

- You can use the following two functions. Refer to Multi-CD Player's Owner's Manual for operation details.
 - * Title display switching
 - * Title scroll
- You cannot switch to the Disc Title Input mode in the Detailed Setting Menu.

Disc Number Search (for 6-Disc, 12-Disc types)

- You can select discs directly with the 1 to 6 buttons.
- Just press the number corresponding to the disc you want to listen to.**

Note:

- When a 12-Disc Multi-CD Player is connected and you want to select disc 7 to 12, press the 1 to 6 buttons for 2 seconds or longer.

Disc Number Rough Search (for 50-Disc type only)

This handy function lets you select discs loaded in a 50-Disc Multi-CD Player using the 1 to 5 buttons. The 50 discs are divided into five blocks, with each of the 1 to 5 buttons assigned to a block.

- Select the desired block with the 1 to 5 button.

Note:

- After completing a rough search, use the ▲ and ▼ buttons to select a desired disc.

Displaying Disc Titles

- Press the DISPLAY button, to change the Disc Title display of the current disc.

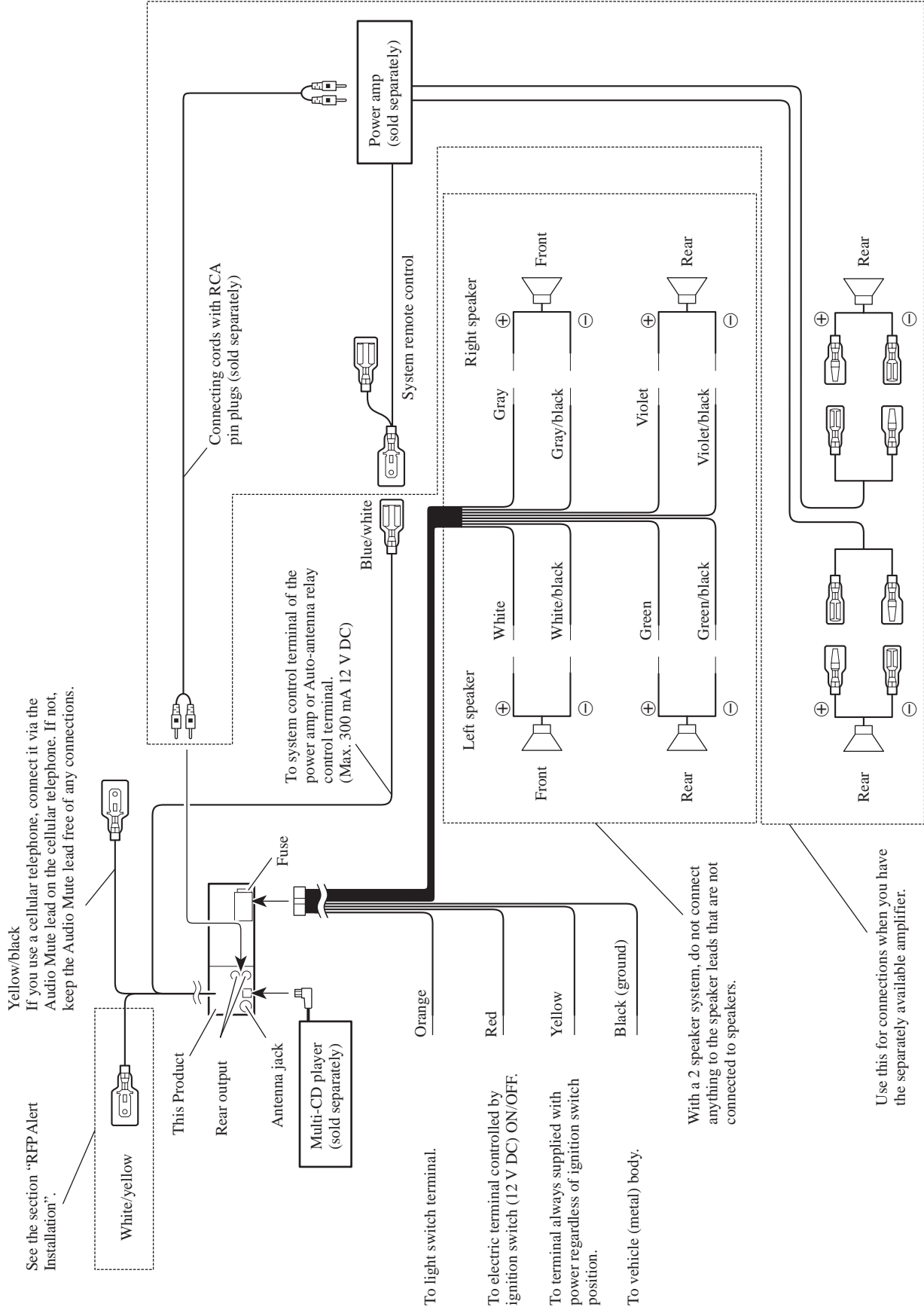

8.2 SPECIFICATIONS

General

Power source 14.4 V DC (10.8 – 15.1 V allowable)
 Grounding system Negative type
 Max. current consumption 10 A
 Dimensions
 (mounting size) 178 (W) × 50 (H) × 155 (D) mm
 (front face) 188 (W) × 58 (H) × 18 (D) mm
 Weight 1.3 kg

Amplifier

Maximum power output 45 W × 4
 Continuous power output 27 W × 4
 (DIN45324, +B = 14.4 V)
 Load impedance 4 Ω (4 – 8 Ω allowable)
 Preout maximum output level/output
 impedance 2.2 V/1 kΩ
 Equalizer (3-Band Parametric Equalizer)
 (Low) Frequency: 40/80/100/160 Hz
 Q Factor: 0.35/0.59/0.95/1.15
 (+6 dB when boosted)
 Level: ±12 dB
 (Mid) Frequency: 200/500/1k/2k Hz
 Q Factor: 0.35/0.59/0.95/1.15
 (+6 dB when boosted)
 Level: ±12 dB
 (High) Frequency: 3.15k/8k/10k/12.5k Hz
 Q Factor: 0.35/0.59/0.95/1.15
 (+6 dB when boosted)
 Level: ±12 dB
 Loudness contour
 (Low) +3,5 dB (100 Hz), +3 dB (10 kHz)
 (Mid) +10 dB (100 Hz), +6,5 dB (10 kHz)
 (High) +11 dB (100 Hz), +11 dB (10 kHz)
 (volume: –30 dB)

Cassette player

Tape Compact cassette tape (C-30 – C-90)
 Tape speed 4.76 cm/sec.(+0.14cm/sec.,-0.05cm/sec.)
 Fast forward/rewinding time Approx. 100 sec. for C-60
 Wow & flutter 0.09% (WRMS)
 Frequency response Metal: 30 – 19,000 Hz (±3 dB)
 (KEH-P7800R)
 Frequency response 30 – 16,000 Hz (±3 dB)
 (KEH-P6800R)
 Stereo separation 45 dB
 Signal-to-noise ratio(KEH-P7800R)
 Metal: Dolby B NR IN: 67 dB (IEC-A network)
 Dolby NR OUT: 61 dB (IEC-A network)
 Signal-to-noise ratio 61 dB (IEC-A network)
 (KEH-P6800R)

FM tuner

Frequency range 87.5 – 108 MHz
 Usable sensitivity
 11 dBf (1.0 μV/75 Ω, mono, S/N: 30 dB)
 50 dB quieting sensitivity 16 dBf (1.7 μV/75 Ω, mono)
 Signal-to-noise ratio 70 dB (IEC-A network)
 Distortion 0.3% (at 65 dBf, 1 kHz, stereo)
 Frequency response 30 – 15,000 Hz (±3 dB)
 Stereo separation 40 dB (at 65 dBf, 1 kHz)

MW tuner

Frequency range 531 – 1,602 kHz
 Usable sensitivity 18 μV (S/N: 20 dB)
 Selectivity 50 dB (±9 kHz)

LW tuner

Frequency range 153 – 281 kHz
 Usable sensitivity 30 μV (S/N: 20 dB)
 Selectivity 50 dB (±9 kHz)

Note:

- Specifications and the design are subject to possible modification without notice due to improvements.